

AVIONICS TEST SOLUTIONS

With increased complexity and integration of aircraft avionics system, having modular and scalable test tools with Ethernet connectivity, either hardwired or wireless LAN can provide simple, cost-efficient solutions for monitoring and simulation resources located both close to and distanced away from the system under test.

Most test solutions comprise of the use of avionic interface modules installed into Industry standard chassis like PXI/PXIe or plugged into a dedicated Host PC platform. The interface modules can then be locally controlled via an embedded PC or the hosting PC resource.

For some cases, the need exists for a high level of compactness and a mixture of avionics databus interfaces with the ability to separate the avionics interfaces from the host PC platform by using a dedicated

compact docking station with plug in modules handling the avionics interfaces. This approach has the advantage to mix and match the required avionics test interfaces to quickly and easily adapt to solve the test needs of a system under test with no impact on the hosting software. This concept provides complete remote control via a PC over an Ethernet LAN network. With an embedded Ethernet switch and optional wifi within a docking station, full scalability is achieved to support many various test scenarios.

The exact same functions as the card and chassis approach can be realized but the advantage is the capability to switch modules from an inventory or share them between applications quickly and easily. In addition, a benefit is that the use of each avionics interface resource can be used as a stand-alone resource with a

small and handy table adaptor. This offers the user both operational and cost savings for today and also the future's avionics test requirements.

With the use of the AIM ADock/ANET Ethernet based test solution and PBA.pro Test and Analysis Software covering MIL-STD-1553, STANAG3910 / EFEX and ARINC429 configurable and scalable avionics testing solutions can be realized for challenging test requirements. \\

Modular Avionics Test Solution with AIM ADock/ANET

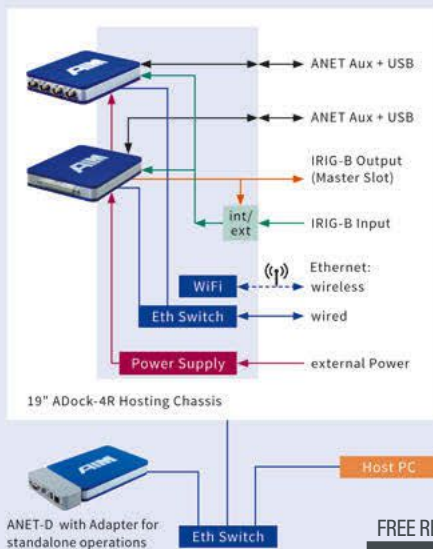

FREE READER INQUIRY SERVICE

AIM

To learn more about this advertiser, visit www.magupdate.co.uk/pati NOW!