



AIM GmbH
Avionics Databus Solutions

MIL-STD-1553 TUTORIAL



AIM GmbH
Sasbacher Str. 2
79111 Freiburg, Germany

Tel: +49-761-45229-0
Fax: +49-761-45229-33

sales@aim-online.com
www.aim-online.com

November 2010
v2.3

Right on Target

MIL-STD-1553 Tutorial

v1.3

December 2002

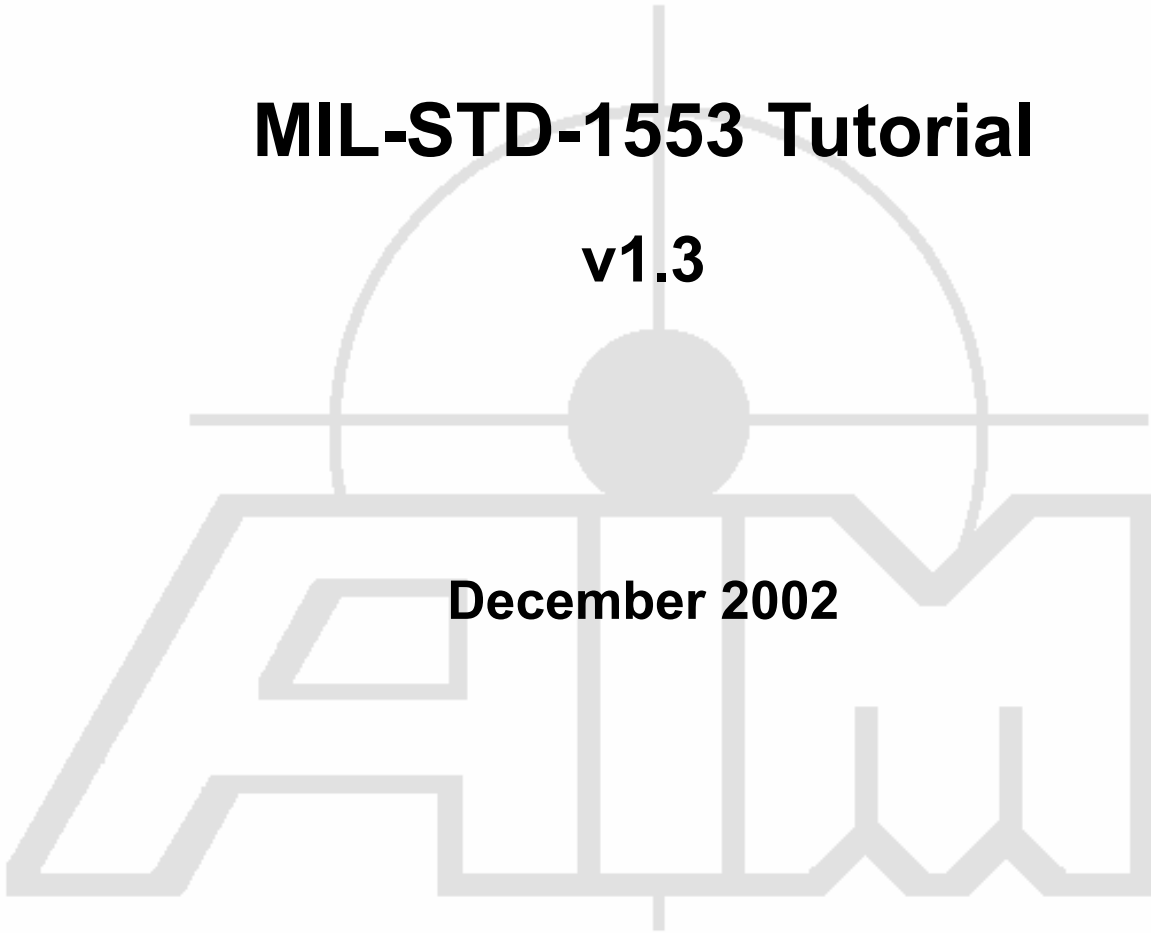

AIM Worldwide

AIM GmbH

Sasbacher Str. 2
79111 Freiburg, Germany
+49-761-45 22 90
sales@aim-online.com

AIM-USA

Seven Neshaminy Interplex
Suite 211
Trevose, PA 19053
267-982-2600
1-877-5201553
salesusa@aim-online.com

Munich Sales Office

Terofalstrasse 23 a
80689 Muenchen, Germany
+49-89-70 92 92 92
salesgermany@aim-online.com

AIM UK

Lincoln Rd, Cressex Business Park
Bucks HP12 3RB, England
+44-1494-44 68 44
salesuk@aim-online.com

Notice: The information that is provided in this document is believed to be accurate. No responsibility is assumed by AIM for its use. No license or rights are granted by implication in connection therewith. Specifications are subject to change without notice.

© Copyright 2001-2002 : AIM

DOCUMENT HISTORY

The following table defines the history of this document. The description of changes/enhancements made to each version is defined in general terms.

Version	Cover Date	Created by	Description
1.0	May 26, 2001	Pat Frodyma	Creation of document
1.1	May 2001	Pat Frodyma	Format Edits
1.2	Feb 2002	Pat Frodyma	Edits to Word Descriptions
1.3	Dec 2002	J. Furgerson	Format/Edits/Incorporation of Notice 1-4 in text
2.3	Nov 2010	B. Waldmann	Update addresses

THIS PAGE INTENTIONALLY LEFT BLANK

TABLE OF CONTENTS

Title	Page
INTRODUCTION	1-1
About This Manual	1-1
Applicable Documents.....	1-2
 MIL-STD-1553 OVERVIEW	 2-1
MIL-STD-1553 History and Application	2-1
1553B Hardware Components.....	2-4
Bus Controller.....	2-4
Remote Terminal	2-4
Bus Monitor	2-5
1553 Cabling	2-5
1553 Coupling	2-5
Direct Coupling.....	2-6
Transformer Coupling.....	2-6
Bus Topology	2-7
MIL-STD-1760C	2-8
1553 Test Procedures.....	2-9
Developmental Testing	2-9
Design Verification.....	2-9
Production Testing.....	2-9
Systems Integration Testing.....	2-9
Field/Operational Testing	2-10
 MIL-STD-1553B SPECIFICATION INTERPRETATION.....	 3-1
1. Scope	3-1
1.1 Scope.....	3-1
1.2 Application.....	3-1
2. Referenced Documents	3-2
2.1 Issue of Document	3-2
3. Definitions	3-3
4. General Requirements.....	3-5
4.1 Test and Operating Requirements	3-5
4.2 Data Bus Operation	3-5
4.3 Characteristics	3-6
4.3.1 Data form.....	3-6
4.3.2 Bit Priority.....	3-6
4.3.3 Transmission Method.....	3-7
4.4 Terminal Operation	3-32
4.4.1 Common Operation.....	3-32
4.4.2 Bus Controller Operation	3-33

4.4.3	Remote Terminal.....	3-33
4.4.4	Bus Monitor Operation.....	3-36
4.5	Hardware Characteristics	3-36
4.5.1	Data Bus Characteristics	3-36
4.5.2	Terminal Characteristics	3-41
Appendix	3-48
10.	General.....	3-48
20.	Referenced Documents	3-50
30.	General Requirements.....	3-50
NOTES	4-1
	Acronyms and Abbreviations	4-1
	Definition of Terms	4-2
APPENDIX A - NOTICES APPLIED TO MIL-STD-1553B.....		10-1
	Notice 1 Overview	10-1
	Notice 2 Overview	10-1
	Notice 3 Overview	10-2
	Notice 4 Overview	10-2

LIST OF FIGURES

Figure	Title	Page
3-1	Bus Components	3-1
3-2	Data Encoding	3-7
3-3	Word Formats.....	3-8
3-4	Command and Status Sync.....	3-9
3-5	Data Sync	3-16
3-6	Information Transfer Formats	3-23
3-7	Broadcast Information Transfer Formats	3-24
3-8	Intermessage Gap and Response Time.....	3-30
3-9	Data Bus Interface Using Transmforer Coupling.....	3-31
3-10	Data Base Interface Using Direct Coupling	3-31
3-11	Coupling Transmformer.....	3-38
3-12	Terminal Input/Output Characteristics for Transformer Coupled Stubs and Direct Coupled Stubs	3-41
3-13	Output Waveform.....	3-45
3-10.1	Possible Redundancy.....	3-48
3-10.2	Possible Redundancy.....	3-48

LIST OF TABLES

Table	Title	Page
2-I	MIL-STD-1553A and MIL-STD-1553B Requirements Comparison.....	2-3
2-II	1553 Cable Characteristics	2-5
2-III	1553 Test Plans for all Components	2-10
3-I	Assigned Mode Codes	3-11
3-II	Criteria for Acceptance or Rejection of a Terminal for the Noise Rejection Test.....	3-44

THIS PAGE INTENTIONALLY LEFT BLANK

INTRODUCTION

About This Manual

This manual was developed to provide a general overview of MIL-STD-1553 its specifications and applications.

The first chapter provides a discussion of MIL-STD-1553, its history, application and operational overview. Included is a reference to MIL-STD-1760C as it applies to Weapon Stores Interface and its relationship to MIL-STD-1553B.

The second chapter includes a complete annotated version of the MIL-STD-1553B specification and an interpretation of the specification contents. The specification is on the top of each page and the AIM interpretation is located on the lower portion of the page. Notices 1 through 4, addendums to the MIL-STD-1553B specification, are summarized at the end of this manual, and have been incorporated into the specification discussed within this document.

AIM provides Commercial-Off-The-Shelf (COTS) products to design, produce, integrate, test and troubleshoot all systems and capabilities mentioned in this MIL-STD-1553 Tutorial as well as for ARINC 429, STANAG 3910, MIL-STD-1760 Applications and Panavia Serial Link. Supported hardware platforms include PC/AT, PCI, Compact PCI, VME, VXI, and PMC.

AIM software products also support full Remote Terminal production testing, full bus analysis and complete system emulation and test capabilities per MIL-STD-1553B specifications.

For detailed information on AIM solutions, visit www.aim-online.com or email salesusa@aim-online.com.

Applicable Documents

The following documents shall be considered to be a part of this document to the extent specified herein.

Industry Documents

MIL-STD-464, Electromagnetic Environmental Effects Requirements for Systems, March 18, 1997

MIL-HDBK-1553A, Multiplex Application Handbook, March 23, 1995

MIL-STD-1553B, Department of Defense Interface Standard for Digital Time Division Command/Response Multiplex Data Bus, Notice 1-4, January 1996

MIL-STD-1760C, Interface Standard for Aircraft/Store Electrical Interconnection System, March 2, 1999

SAE AS4111, Validation Test Plan for the Digital Time Division Command/Response Multiplex Data Bus Remote Terminals, October 1998

SAE AS4112, Production Test Plan for the Digital Time Division Command/Response Multiplex Data Bus Remote Terminals, January 1989

SAE AS4113, Validation Test Plan for the Digital Time Division Command/Response Multiplex Data Bus Controllers, January 1989

SAE AS4114, Production Test Plan for the Time Division Command/Response Multiplex Data Bus Controllers, January 1989

SAE AS4115,, Test Plan for the Digital Time Division Command/Response Multiplex Data Bus System, January 1989

SAE AS4116, Test Plan for the Digital Time Division Command/Response Multiplex Data Bus Bus Monitors, September 1990

SAE AS4117, Test Plan for the Digital Time Division Command/Response Multiplex Data Bus Couplers, Terminators, and Data Bus Cables, March 1991

AIM Product Specific Documents

None

MIL-STD-1553 OVERVIEW

MIL-STD-1553B is the military specification defining a Digital Time Division Command/Response Multiplexed Data Bus. The 1553 databus is a dual-redundant, bi-directional, Manchester II encoded databus with a high bit error reliability. All bus communications are controlled and initiated by a main bus controller. Remote terminal devices attached to the bus respond to controller commands.

MIL-STD-1553B defines specifications for terminal device operation and coupling, word structure and format, messaging protocol and electrical characteristics.

MIL-STD-1553 History and Application

MIL-STD-1553B was developed from the growing complexity of integrated avionics systems and the subsequent increase in the number of discrete interconnects between terminal devices. Direct point-to-point wiring became complex, expensive and bulky, requiring definition of a multiplex data bus standard. The first draft of a standard in 1968

by the Aerospace Branch of the Society of Automotive Engineers (SAE) laid the foundation for the US Air Force's adoption of MIL-STD-1553 in 1973.

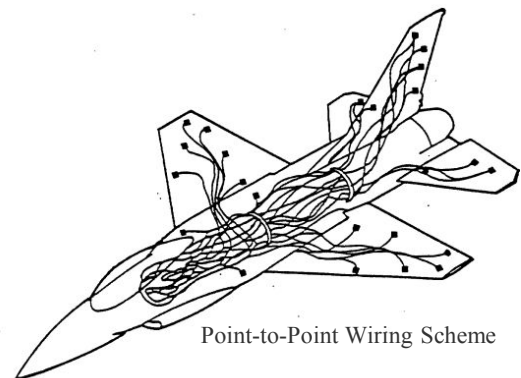

A tri-service version, MIL-STD-1553A was released in 1975, modified to MIL-STD-1553B in 1978 and utilized in the Air Force F-16 and the United States (US) Army AH-64A Apache Attack Helicopter. Notice 2, released in 1986 and superceded Notice 1 released in 1980, is a tri-service standard for RT design specs and defines how some bus options are to be used. Notices 3 and 4 did not alter the contents of the standard, but only provided a title change. MIL-STD-1553B has become the internationally accepted networking standard for integrating military platforms. Table 2-I shows the differences between MIL-STD-1553A and MIL-STD-1553B.

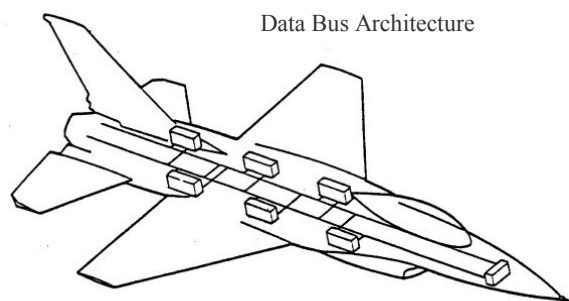

Military services and contractors originally adopted MIL-STD-1553 as an avionics data bus due to its highly reliable, serial, 1 Megabit per sec (Mbps) transfer rate and extremely low error rate of 1 word fault per 10 million words, on a dual-redundant architecture.

This reliability has proven equally effective on communication networks in submarines, tanks, target drones, missile and satellite systems,

land-based and launch vehicles, and space system including the current International Space Station and Shuttle programs.

MIL-STD-1553B defines the data bus structure for interconnection of up to 31 remote terminal (RT) devices. A single controller device on the bus initiates the command/response communication with the remote devices. The remote and control devices are interconnected over two, separate buses. Normal operation involves only the primary bus with the secondary bus available as redundant backup in the event of primary bus damage or failure.

Standardization of a set of specifications for a military data bus provides two major advantages:

- a. Significant size/weight savings of interconnected devices and cabling
- b. Reduced development and modification costs with compatible devices.

Table 2-I MIL-STD-1553A and MIL-STD-1553B Requirements Comparison

Specification Requirement	MIL-STD-1553A	MIL-STD-1553B
Cable Type	Jacketed, shielded twisted pair	Jacketed, shielded twisted pair
Cable Shield Coverage – minimum	80%	75%
Cable Twist – minimum	12 twists/foot	4 twists/foot
Capacitance, wire to wire – maximum	30 pF/ft	30 pF/ft
Characteristic Cable Impedance (Z_0)	$70 \Omega \pm 10\% @ 1 \text{ MHz}$	$70\text{-}80 \Omega \pm 10\% @ 1 \text{ MHz}$ Nominal
Cable Attenuation	1 dB/100 ft @ 1 MHz	1.5 dB/100 ft @ 1 MHz
Cable Length	300 ft – maximum	Unspecified
Cable Termination	Characteristic Impedance	Nominal Characteristic Impedance $\pm 2\%$
Cable Stubbing	Direct Coupling < 1 ft Transformer Coupling 1 – 20 ft	Direct Coupling < 1 ft Transformer Coupling 1 – 20 ft
Cable Coupling Shield	Shielded coupler box	75% coverage – minimum
Coupling Transformer Turns Ratio	Unspecified	1:141 $\pm 3\%$ with higher Turns on isolation resistor side
Transformer Open Circuit Impedance	Unspecified	3 k Ω from 75 kHz – 1 MHz With 1 V RMS sine wave
Transformer Waveform Integrity	Unspecified	Droop of 20% overshoot – max Ringing of $\pm 1 \text{ V}$ peak – max
Transformer Common Mode Rejection	Unspecified	45 dB @ 1 MHz
Fault Isolation Isolation Resistors in series with coupler Direct Coupled	$R = 0.75 Z_0 \pm 5\%$ $R = 0.75 Z_0 \pm 5\%$	$R = 0.75 Z_0 \pm 2\%$ $R = 55 \Omega \pm 2\%$
Impedance across bus with failed Transformer coupling component Direct coupling	No less than $1.5 Z_0$ Unspecified	No less than $1.5 Z_0$ No less than 110 Ω
Stub Voltage Requirement Transformer Coupled Direct Coupled	1 V to 20 V peak to peak 1 V to 20 V peak to peak	1 V to 14 V peak to peak 1.4 V to 20 V peak to peak

1553B Hardware Components

MIL-STD-1553B defines three types of terminal devices that are allowed on the bus:

- a. Bus Controller (BC)
- b. Remote Terminal (RT)
- c. Bus Monitor (BM).

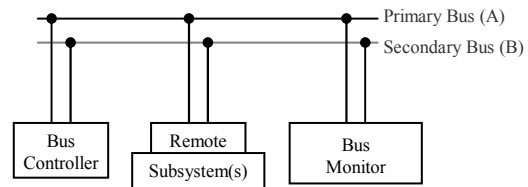

Bus Controller

The main function of the bus controller (BC) is to provide data flow control for all transmissions on the bus. In addition to initiating all data transfers, the BC must transmit, receive and coordinate the transfer of information on the data bus. All information is communicated in command/response mode - the BC sends a command to the RTs, which reply with a response.

The bus controller, according to MIL-STD-1553B, is the “key part of the data bus system” and “the sole control of information transmission on the bus shall reside with the bus controller, which shall initiate all transmission”. The bus can support multiple BCs, but only one can be active at a time.

Normal BC data flow control includes transmitting commands to RTs at predetermined time intervals. The commands may include data or requests for data (including status) from RTs. The BC has control to modify the flow of bus data based on changes in the operating environment. These changes could be a result of an air-to-ground attack mode changing to air-to-air, or the failure mode of a hydraulic system. The BC is responsible for detecting these changes and initiating action to counter them. Error detection may require the BC to attempt communications to the RT on the redundant, backup bus.

Remote Terminal

The remote terminal (RT) is a device designed to interface various subsystems with the 1553 data bus. The interface device may be embedded within the subsystem itself, or be an external interface to tie a non-1553 compatible device to the bus. As a function of the interface requirement, the RT receives and decodes commands from the BC, detects any errors and reacts to those errors. The RT must be able to properly handle both protocol errors (missing data, extra words, etc) and electrical errors (waveform distortion, rise time violations, etc). RTs are the largest segment of bus components. RT characteristics include:

- a. Up to 31 remote terminals can be connected to the data bus
- b. Each remote terminal can have 31 subaddresses
- c. No remote terminal shall speak unless spoken to first by the bus controller and specifically commanded to transmit

Bus Monitor

The bus monitor (BM) listens to all messages on the bus and records selected activities. The BM is a passive device that collects data for real-time or post capture analysis. The BM can store all or portions of traffic on the bus, including electrical and protocol errors. BMs are primarily used for instrumentation and data bus testing.

1553 Cabling

The MIL-STD-1553B definition of a data bus is “a twisted-shielded pair transmission line made up of a main bus and a number of attached stubs”. Shielding limits signal interference from outside sources and the twisted pair maintains message integrity through noise canceling.

MIL-STD-1553B specifies that all devices in the system will be connected to a redundant pair of buses, providing an alternate data path in the event of damage or failure of the primary bus path. Bus messages only travel on one of the buses at a time, determined by the bus controller.

Cable Type	Twisted Shielded Pair
Capacitance	30 pF/ft _{max}
Cable Impedance	70-85 Ω at 1 MHz
Cable Attenuation	1.5 dB per 100 ft at 1 MHz _{max}
Twist Ratio	4 per foot _{min}
Shield Coverage	75% _{min}
Cable Termination	Cable Impedance \pm 2%

Properly terminating the main data bus on each end makes the bus appear like an infinite line. Stub loading effects can be minimized on the bus by properly designed coupling. Table 2-II lists the 1553 cable characteristics.

1553 Coupling

Coupling connects a terminal device to the main data bus via interconnecting buses called stubs. Connecting terminals create a load on the main bus, creating impedance mismatches and resultant signal reflections that can distort and degrade signal quality on the bus. System error rate performance and good signal to noise ratio require a balance between stub impedance being low enough to provide adequate terminal signal levels but high enough to reduce signal distortion from reflections. MIL-STD-1553B allows two methods of coupling terminal devices to the main bus:

- a. Direct coupling
- b. Transformer coupling.

Direct Coupling

Direct coupling connections are wired directly to the bus cabling. The isolation resistors and transformer are internal to the terminal device, not requiring additional coupling hardware. Direct coupling connections can only be used with stub lengths of less than 1 foot.

Isolation resistors provide some protection for the main bus in the event of a stub or terminal short, but MIL-STD-1553B cautions the use of direct coupling because a terminal short could disable the entire bus. Direct stubs can also cause significant impedance mismatches on the bus.

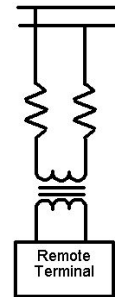

Transformer Coupling

Transformer coupling utilizes a second isolation transformer, located external to the terminal device, in its own housing with the isolation resistors. Transformer coupling extends the stub length to 20 feet and provides electrical isolation, better impedance matching and higher noise rejection characteristics than direct coupling. The electrical isolation prevents a terminal fault or stub impedance mismatch from affecting bus performance.

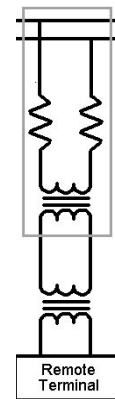

Bus Topology

Bus topology refers to the physical layout and connections of each device attached to the data bus. Single level topologies are the most basic, easy to design and widely implemented layouts with all terminal devices connected to a single bus.

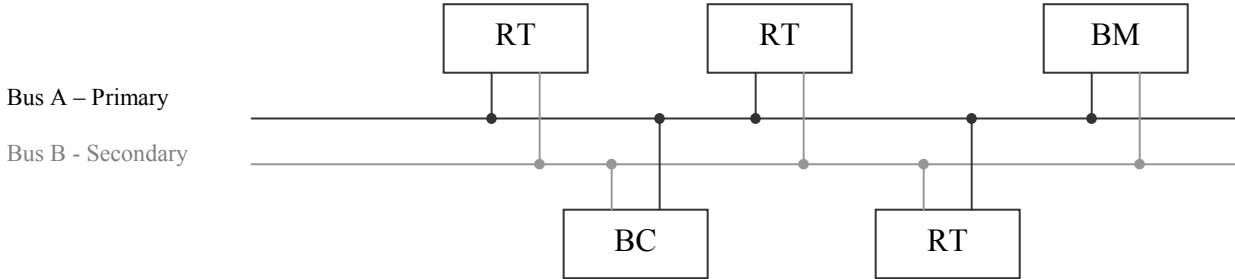

Multiple level topologies are designed by interconnecting single level buses so data from one bus can be transferred on another bus. Buses interconnected in a multiple level topology can have equal control over data flow, which helps retain autonomy for each bus with the greatest isolation between them. A hierarchical format between multiple level buses establishes local (subordinate) buses and global (superior) buses with the global bus having control over local, subordinate buses.

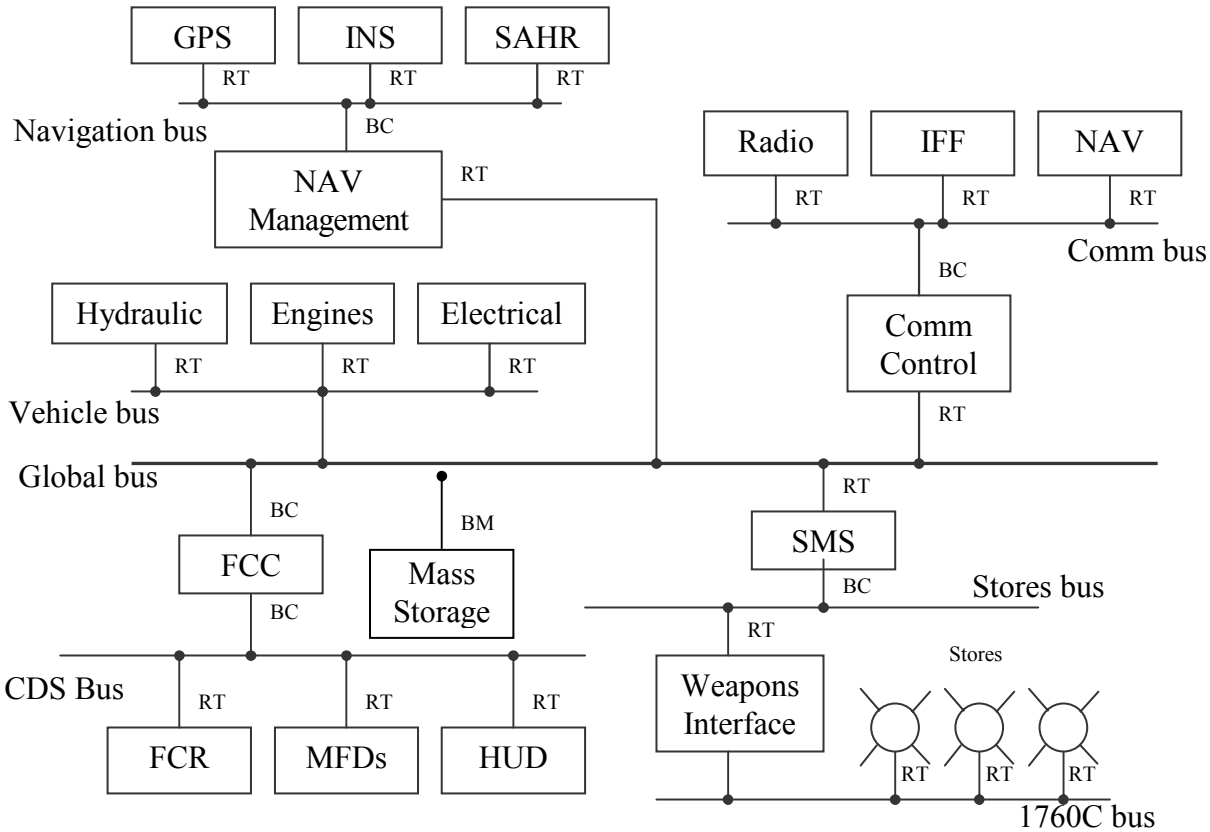

MIL-STD-1760C

MIL-STD-1760C, released April 15, 1991 defines implementation requirements for the Aircraft/Store Electrical Interconnection System (AEIS) between aircraft and stores. A store is any external device attached to the aircraft and includes permanent devices – ECM, LANTIRN, fuel tanks – and devices designed to separate – bombs, missiles, etc.

MIL-STD-1760C states “the data bus interface shall comply with the requirements of MIL-STD-1553” with some additional requirements. In this case, the 1553 bus is the controlling bus over the subordinate 1760 AEIS bus. That 1760 bus may then control a 1553 bus system within a store to communicate directly with weapons, navigational aids or communications subsystems.

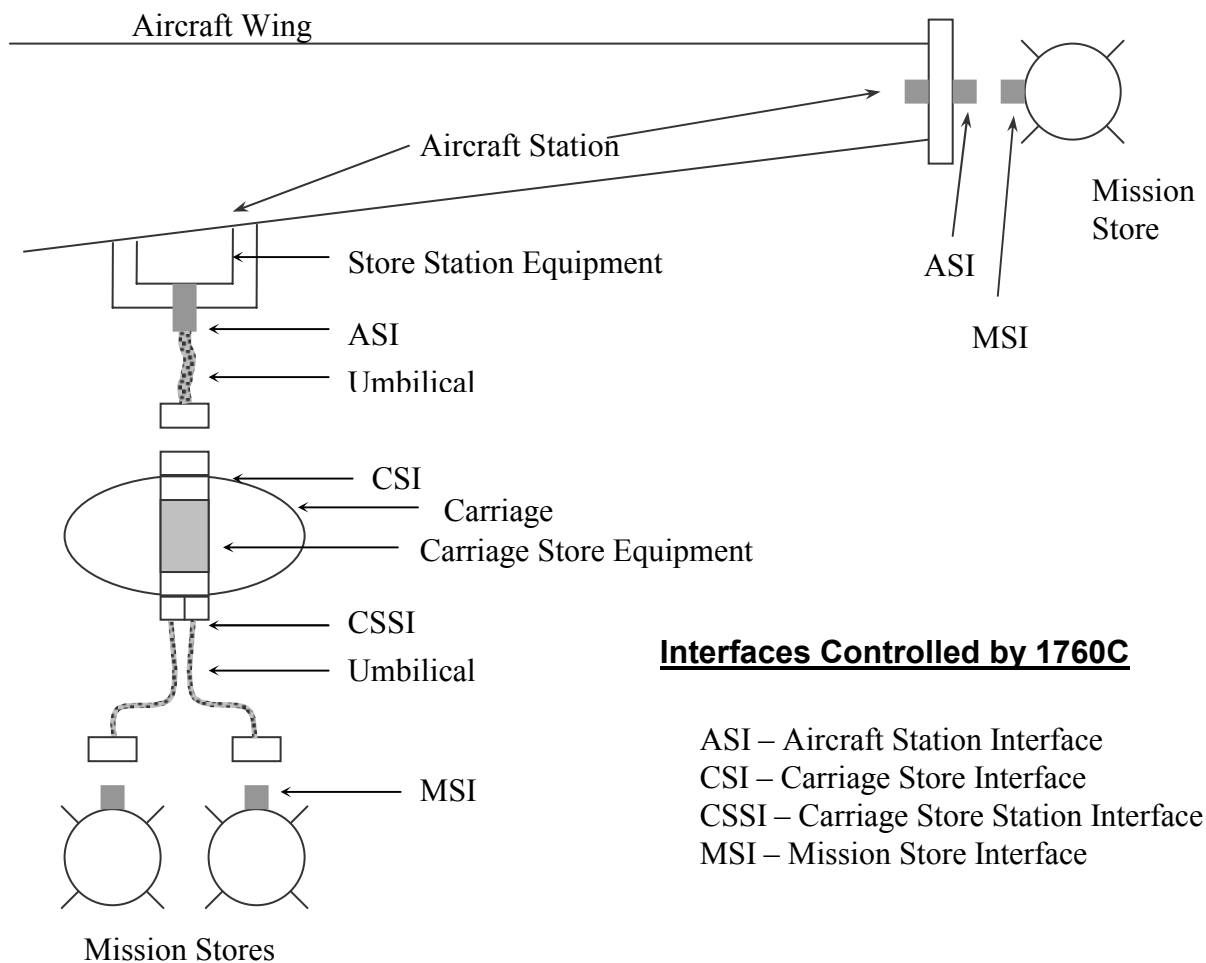

The Aircraft Station Interface (ASI) is the connection to the aircraft. Umbilical cabling connects the ASI to the store connector, the Mission Store Interface (MSI). The ASI can also connect – through an umbilical cable – to a Carriage Store Interface (CSI) to tie in multiple mission stores. Carriage Store Station Interfaces (CSSI) then connects to MSIs via umbilical cables.

Mission stores contain embedded 1553 RTs that must be capable of BC-RT, RT-BC and RT-RT message transfers with the aircraft functioning as the bus controller. Dynamic bus control is not allowed on a MIL-STD-1760C bus design.

1553 Test Procedures

Testing MIL-STD-1553B components validate the functional capability of the bus design. Testing the design of a bus requires testing message formats, mode commands, status word bits and coupling techniques as they apply to each remote terminal, bus controller and monitor device. Five levels of testing have been developed to verify MIL-STD-1553B bus design compliance:

- a. Developmental Testing
- b. Design Verification
- c. Production Testing
- d. Systems Integration Testing
- e. Field/Operational Testing.

Developmental Testing

Developmental Testing is implemented at the circuit level to determine operational capability of the circuit design. Standard test techniques also validate operating characteristics over the required environmental operating range – i.e. temperature, humidity, vibration, etc.

Design Verification

Design Verification is carried out on pre-production prototypes to insure 1553 compliance, as well as systems specifications on the design unit itself. This testing level verifies hardware/software requirements before production begins.

Production Testing

Production Testing is performed on production equipment as a final Quality Assurance check or during the production process on subassembly items. Often applying a subset of the design verification tests, Production Testing verifies circuit operation and proper sequence operations such as error message validation and mode code operation.

Systems Integration Testing

Systems Integration Testing is applied while integrating bus components into a system and insures interoperability of the joined components. During Systems Integration Testing, network hardware and software are combined and assessed to insure proper data flow control.

Field/Operational Testing

Field/Operational Testing is implemented as a final design test of the system under actual operating conditions. Known as Developmental Test/Operational Test – DT/OT – this level of testing verifies operational integrity of the components/system in installed, fully functional bus networks.

The Society of Automotive Engineers (SAE) in conjunction with the government has developed a series of Test Plans for all 1553 components as listed in Table 2-III.

Table 2-III 1553 Test Plans for all Components

Test Plan	Document Number
Remote Terminal Validation Test Plan – Section 100	MIL-HDBK-1553A
Remote Terminal Validation Test Plan	SAE AS4111
Remote Terminal Production Test Plan	SAE AS4112
Bus Controller Validation Test Plan	SAE AS4113
Bus Controller Production Test Plan	SAE AS4114
Data Bus System Test Plan	SAE AS4115
Bus Monitor Test Plan	SAE AS4116
Bus Components Test Plan	SAE AS4117

MIL-STD-1553B SPECIFICATION INTERPRETATION

The following numbered sections are lifted from MIL-STD-1553B with Notices 1-4 incorporated. All Notice 1 changes were superseded by Notice 2 changes. Notice 2 changes are noted with two asterisks (**). (Notices 3 and 4 do not affect the body of the text.) Below each group of numbered sections is an interpretation provided by AIM to aid the reader in a better understanding of the MIL-STD-1553B specification.

1. Scope

1.1 Scope

This standard establishes requirements for digital, command/response, time division multiplexing (Data bus) techniques**. It encompasses the data bus line and its interface electronics illustrated on Figure 3-1, and also defines the concept of operation and information flow on the multiplex data bus and the electrical and functional formats to be employed.

1.2 Application

When invoked in a specification or statement of work, these requirements shall apply to the multiplex data bus and associated equipment which is developed either alone or as a portion of a** weapon system or subsystem development. The contractor is responsible for invoking all the applicable requirements of this Military Standard and any and all subcontractors he may employ.

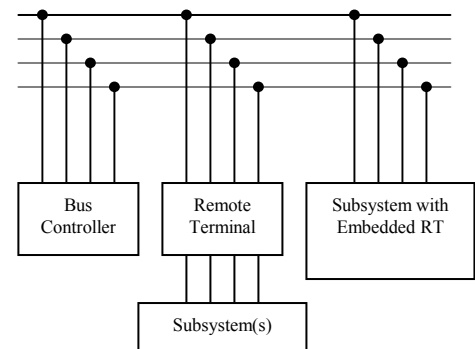

Figure 3-1 – Bus Components

Specification

Interpretation

MIL-STD-1553B defines the requirements for a digital data bus and interface requirements.

The original standard addressed only the avionics data bus applications of 1553. The current revision, MIL-STD-1553B, Notice 4, has grown to tri-service adoption with applications in all facets of national and international military craft.

Some sections of the original standard have been modified, first by Notice 1 – released in 1980 – then were superseded by the publication of Notice 2 in 1986. Sections affected by these releases will be notated in this interpretation.

***Notice 2 changes due to incorporation of tri-service application which resulted in deletion of aircraft reference.*

2. Referenced Documents

2.1 Issue of Document

The following document, of the issue in effect on the date of invitation for bid or request for proposal, forms a part of the standard to the extent specified herein.

MIL-E-6051 Electromagnetic Compatibility Requirements, Systems



MIL-E-6051 is a Military Standard defining Electromagnetic Compatibility between systems. MIL-STD-1553B references MIL-E-6051 in paragraph 4.3.3.2.1 regarding the electrical characteristics of the main bus data cable. MIL-E-6051 has since been superseded by MIL-STD-464, Electromagnetic Environmental Effects Requirements for Systems.

MIL-STD-1760C is a Military Standard defining equipment for the Aircraft/Store Electrical Interconnection System (AEIS) between aircraft and stores. Although not mentioned in the MIL-STD-1553B standard (1760C was issued in 1991), 1553B is utilized in that standard as the control path for the stores.

3. Definitions

3.1 Bit

Contraction of binary digit: may be either zero or one. In information theory a binary digit is equal to one binary decision or the designation of one of two possible values or states of anything used to store or convey information.

3.2 Bit Rate

The number of bits transmitted per second.

3.3 Pulse Code Modulation (PCM)

The form of modulation in which the modulation signal is sampled, quantized, and coded so that each element of information consists of different types or numbers of pulses and spaces.

3.4 Time Division Multiplexing (TDM)

The transmission of information from several signal sources through one communication system with different signal samples staggered in time to form a composite pulse train.

3.5 Half Duplex

Operation of a data transfer system in either direction over a single line, but not in both directions on that line simultaneously.

3.6 Word

In this document a word is a sequence of 16 bits *plus sync and parity*. There are three types of words: command, status and data.

3.7 Message

A single message is the transmission of a command word, status word, and data words if they are specified. For the case of a remote terminal to remote terminal (RT to RT) transmission, the message shall include the two command words, the two status words, and data words.

3.8 Subsystem

The device or functional unit receiving data transfer service for the data bus.

3.9 Data Bus

Whenever a data bus or bus is referred to in this document it shall imply all the hardware including twisted shielded pair cables, isolation resistors, transformers, etc., required to provide a single data path between the bus controller and all the associated remote terminals.

3.10 Terminal

The electronic module necessary to interface the data bus with the subsystem and the subsystem with the data bus. Terminals may exist as separate line replaceable units (LRU's) or be contained within the elements of the subsystem.

3.11 Bus Controller (BC)

The terminal assigned the task of initiating information transfers on the data bus.

3.12 Bus Monitor (BM)

The terminal assigned the task of receiving bus traffic and extracting selected information to be used at a later time.

3.13 Remote terminal (RT)

All terminals not operating as the bus controller or as a bus monitor.

3.14 Asynchronous Operation

For the purpose of this standard, asynchronous operation is the use of an independent clock source in each terminal for message transmission. Decoding is achieved in receiving terminals using clock information derived from the message.

3.15 Dynamic Bus Control

The operation of a data bus system in which designated terminals are offered control of the data bus.

3.16 Command/Response

Operation of a data bus system such that remote terminals receive and transmit data only when commanded to do so by the bus controller.

3.17 Redundant Data Bus

The use of more than one data bus to provide more than one data path between the subsystems, i.e., dual redundant data bus, tri-redundant data bus, etc.

3.18 Broadcast

Operation of a data bus system such that information transmitted by the bus controller of a remote terminal is addressed to more than one of the remote terminals connected to the data bus.

3.19 Mode Code

A means by which the bus controller can communicate with the multiplex bus related hardware, in order to assist in the management of information flow.

4. General Requirements

4.1 Test and Operating Requirements

All requirements as specified herein shall be valid over the environmental conditions which the multiplex data bus system shall be required to operate.

4.2 Data Bus Operation

The multiplex data bus system in its most elemental configuration shall be as shown on Figure 3-1. The multiplex data bus system shall function asynchronously in a command/response mode, and transmission shall occur in a half-duplex manner. Sole control of information transmission on the bus shall reside with the bus controller, which shall initiate all transmissions. The information flow on the data bus shall be comprised of messages, which are, in turn, formed by three types of words (command, data, and status) as defined in 4.3.3.5.



The following General Requirements outline Data Bus Operations as it applies to this standard.

MIL-STD-1553B defines the data bus system as having asynchronous, half duplex communications in a command/response mode.

Command/response mode means that the bus controller initiates all messages on the bus and no terminal device transmits to the bus without first being commanded to do so.

General information flow on the bus is comprised of messages, made up of three different types of words: command, data and status.

Word types are defined in 4.3.3.5.

4.3 Characteristics

4.3.1 Data form

Digital data may be transmitted in any desired form, provided that the chosen form shall be compatible with the message and word formats defined in this standard. Any unused bit positions in a word shall be transmitted as logic zeros.

4.3.2 Bit Priority

The most significant bit shall be transmitted first with the less significant bits following in descending order of value in the data word. The number of bits required to define a quantity shall be consistent with the resolution or accuracy required. In the event that multiple precision quantities (information accuracy or resolution requiring more than 16 bits) are transmitted, the most significant bits shall be transmitted first, followed by the word(s) containing the lesser significant bits in numerical descending order. Bit packing of multiple quantities in a single data word is permitted.



The Characteristics section of the General Requirements begins to develop strict guidelines for word formats, commands, message timing and response times.

Data words transmit 16 bits of data, with the most significant bit (MSB) being transmitted first. There is no other standard describing the content of a data word. Content and format vary from application to application. Most bus architectures have a self-defined standard for their particular word formats.

4.3.3 Transmission Method

4.3.3.1 Modulation

The signal shall be transferred over the data bus in serial digital pulse code modulation form.

4.3.3.2 Data Code

The data code shall be Manchester II bi-phase level. A logic one shall be transmitted as a bipolar coded signal 1/0 (i.e., a positive pulse followed by a negative pulse). A logic zero shall be a bipolar coded signal 0/1 (i.e., a negative pulse followed by a positive pulse). A transition through zero occurs at the midpoint of each bit time (see Figure 3-2).

4.3.3.3 Transmission Bit Rate

The transmission bit rate on the bus shall be 1.0 Megabit per second with a combined accuracy and long-term stability of $\pm 0.1\%$ (i.e., ± 1000 hertz). The short-term stability (i.e., stability over 1.0 second interval) shall be at least 0.01% (i.e., ± 100 hertz).

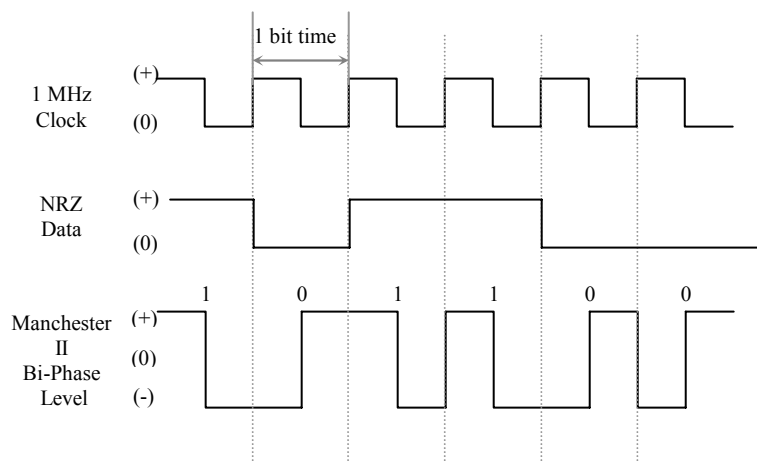

Figure 3-2 – Data Encoding

4.3.3.4 Word Size

The word size shall be 16 bits plus the sync waveform and the parity bit for a total of 20 bits as shown on Figure 3-3.



Bits are encoded on a bi-phase Manchester II format. This provides a self-clocking waveform with equal positive and negative values. Manchester encoding uses the timing and polarity of the zero crossing point to signal data on the bus, not the voltage levels of the signal.

Figure 3-2 shows the differences between a Non-Return to Zero (NRZ) waveform versus the Manchester II format. Note that the NRZ does not transition every bit time.

Manchester waveforms transition at the center of the bit time. A logic 0 goes from negative to positive during that transition. A logic 1 goes from positive to negative. With transitions every bit cycle, the Manchester II provides greater reliability than a typical NRZ waveform.

4.3.3.5 Word Formats

The word formats shall be as shown on Figure 3-3 for the command, data, and status words.

4.3.3.5.1 Command Word

A command word shall be comprised of a sync waveform, remote terminal address field, transmit/receive (T/R) bit, Subaddress/mode field, word count/mode code field, and a parity (P) bit (see Figure 3-3).

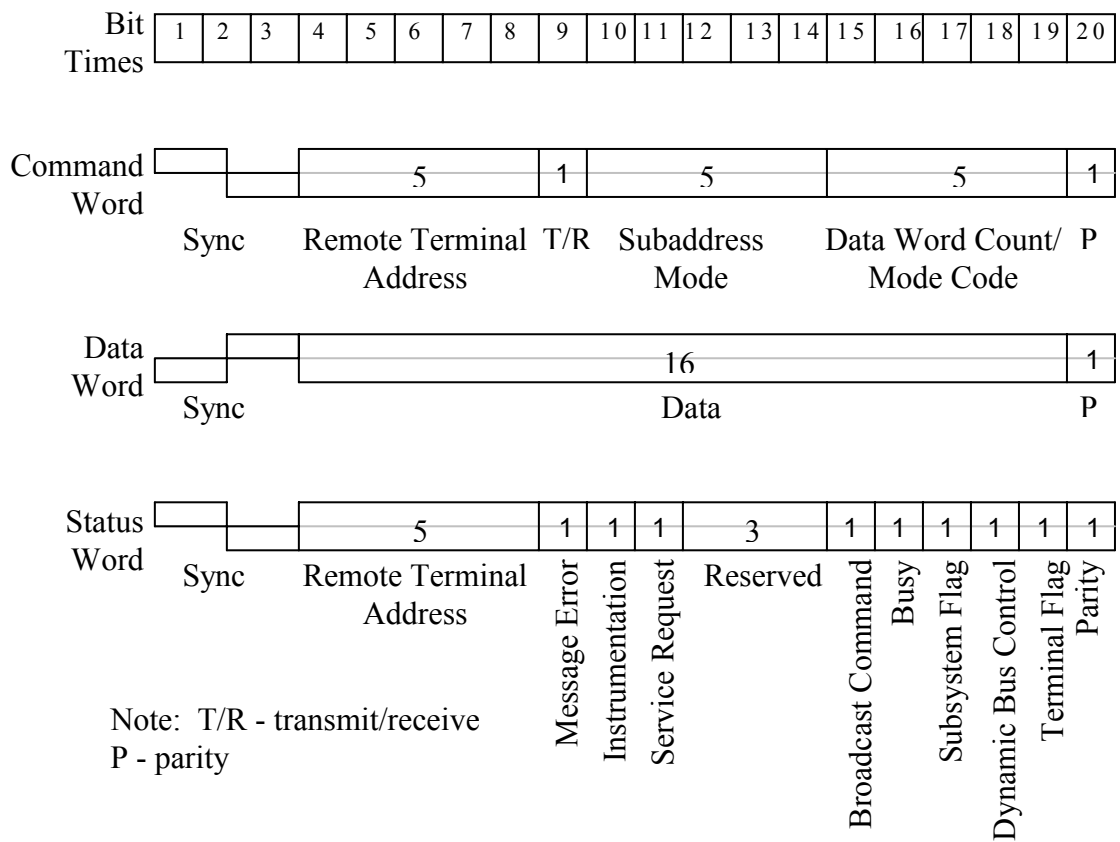

Figure 3-3 – Word Formats

4.3.3.5.1.1 Sync

The command sync waveform shall be an invalid Manchester waveform as shown on Figure 3-4. The width shall be three bit times, with the sync waveform being positive for the first one and one-half bit times, and then negative for the following one and one-half bit times. If the next bit following the sync waveform is a logic zero, then the last half of the sync waveform will have an apparent width of two clock periods due to the Manchester encoding.

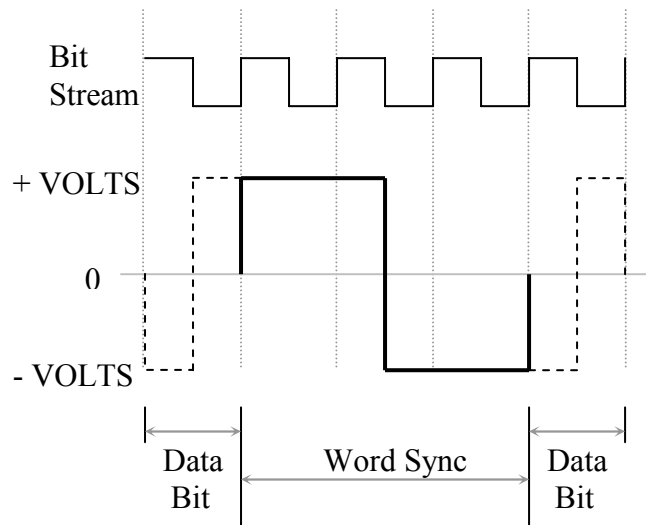

Figure 3-4 – Command and Status Sync

4.3.3.5.1.2 Remote Terminal Address

The next five bits following the sync shall be the RT address. Each RT shall be assigned a unique address. Decimal address 31 (11111) shall not be assigned as a unique address. In addition to its unique address, a RT shall be assigned decimal address 31 (11111) as the common address, if the broadcast option is used.

Specification

Interpretation

Command words are transmitted by the bus controller to remote terminals to instruct them to receive data, transmit data or perform some other operation. Commands are sent to aid in data bus management, electrical control of an RT and standard data transfers. Command words are only transmitted by the active bus controller.

Each RT connected in a system is assigned a unique address. With five available address bits, 2^5 allows for 32 unique addresses (0-31). The remote terminal examines the address field of all incoming commands, and if the address field matches the RT address, that RT acts on the remainder of the command. RT address 31 (11111) was defined as the Broadcast RT. Individual RTs can enable or disable the processing of broadcast messages (a message to all system RTs), but no RT can respond to the broadcast message as a singular RT. This limits the number of RTs in a 1553B bus system to 31, plus the broadcast address.

4.3.3.5.1.3 Transmit/Receive

The next bit following the remote terminal address shall be the T/R bit, which shall indicate the action required of the RT. A logic zero shall indicate the RT is to receive, and a logic one shall indicate the RT is to transmit.

4.3.3.5.1.4 Subaddress/Mode

The next five bits following the T/R bit shall be utilized to indicate an RT Subaddress or use of mode control, as is dictated by the individual terminal requirements. The Subaddress/mode values of 0 (00000) and 31 (11111) are reserved for special purposes, as specified in 4.3.3.5.1.7, and shall not be utilized for any other function.

4.3.3.5.1.5 Data Word Count/Mode Code

The next five bits following the Subaddress/Mode field shall be the quantity of data words to be either sent out or received by the RT or the optional mode code as specified in 4.3.3.5.1.7. A maximum of 32 data words may be transmitted or received in any one message block. All 1's (11111) shall indicate a decimal count of 31, and all 0's (00000) shall indicate a decimal count of 32.

4.3.3.5.1.6 Parity

The last bit in the word shall be used for parity over the preceding 16 bits. Odd parity shall be utilized.

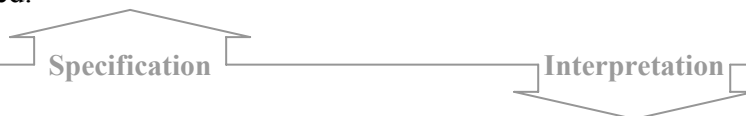

The T/R bit indicates the action requested of the RT. This bit is set from the RT's perspective, meaning a 1 bit requests the RT to transmit data, a 0 requests the RT to receive data following the command.

A Subaddress is a function or area within the RT to which the command is being directed. The Subaddress directs the RT to a specific grouping of data to be transmitted onto the bus, or it indicates what the RT is to do with the data it is about to receive. MIL-STD-1553B sets aside two special subaddresses: Subaddress 0 and Subaddress 31. They are reserved for Mode code (or Mode commands).

Mode commands are special messages that utilize the five-bit Word Count field as a Mode Code field. These messages are sent to specific RTs to check their status, control their operation and manage the bus. Mode commands exchange at most one data word, and may involve no data words at all.

The Data Word Count/Mode Code is another dual function field, determined by the contents in the Subaddress/Mode field. Up to 32 data words can be transmitted in a message.

Parity checks for bit errors during transmission. The total number of bits for any word exchanged, excluding the sync bits and including the parity bit, should be odd.

4.3.3.5.1.7 Optional Mode Control

For RTs exercising this option a Subaddress/mode code of 0 (00000) or 31 (11111) shall imply that the contents of the data word count/mode code field are to be decoded as a five bit mode command. The mode code shall only be used to communicate with the multiplex bus related hardware, and to assist in the management of information flow, and not to extract data from or feed data to a functional subsystem. Codes 00000 through 01111 shall only be used for mode codes which do not require transfer of a data word. For these codes, the T/R bit shall be set to 1. Codes 10000 through 11111 shall only be used for mode codes which require transfer of a single data word. For these mode codes, the T/R bit shall indicate the direction of data word flow as specified in 4.3.3.5.1.3. No multiple data word transfer shall be implemented with any mode code. The mode codes are reserved for the specific functions as specified in Table 3-I and shall not be used for any other purpose. If the designer chooses to implement any of these functions, the codes, T/R bit assignments, and use of a data word, shall be used as indicated. The use of the broadcast command option shall only be applied to particular mode codes as specified in Table 3-I.

Table 3-I – Assigned Mode Codes

T/R Bit	Mode Code	Function	Associated Data Word	Broadcast Command Allowed
1	00000	Dynamic Bus Control	N	N
1	00001	Synchronize	N	Y
1	00010	Transmit Status Word	N	N
1	00011	Initiate Self Test	N	Y
1	00100	Transmitter Shutdown	N	Y
1	00101	Override Transmitter	N	Y
1	00110	Inhibit Terminal Flag Bit	N	Y
1	00111	Override Inhibit Terminal Flag Bit	N	Y
1	01000	Reset RT	N	Y
1	01001	Reserved	N	TBD
↓ ↓ ↓ ↓				
1	01111	Reserved	N	TBD
1	10000	Transmit Vector Word	Y	N
0	10001	Synchronize	Y	Y
1	10010	Transmit Last Command	Y	N
1	10011	Transmit BIT Word	Y	N
0	10100	Selected Transmitter	Y	Y
0	10101	Override Selected Transmitter	Y	Y
1 or 0	10110	Reserved	Y	TBD
↓ ↓ ↓ ↓				
1 or 0	11111	Reserved	Y	TBD



When the Subaddress/Mode field is 0 (00000) or 31 (11111) the Word Count/Mode Code field identifies the mode code.

4.3.3.5.1.7.1 Dynamic Bus Control

The controller shall issue a transmit command to an RT capable of performing the bus control function. This RT shall respond with a status word as specified in 4.3.3.5.3. Control of the data bus passes from the offering bus controller to the accepting RT upon completion of the transmission of the status word by the RT. If the RT rejects control of the data bus, the offering bus controller retains control of the data bus.

4.3.3.5.1.7.2 Synchronize (without a data word)

This command shall cause the RT to synchronize (e.g., to reset the internal timer, to start a sequence, etc.). The RT shall transmit the status word as specified in 4.3.3.5.3.

4.3.3.5.1.7.3 Transmit Status Word

This command shall cause the RT to transmit the status word associated with the last valid command word preceding this command. This mode command shall not alter the state of the status word.

4.3.3.5.1.7.4 Initiate Self Test

This command shall be used to initiate self-test within the RT. The RT shall transmit the status word as specified in 4.3.3.5.3.



Specification

Interpretation

A Dynamic bus control mode command allows the active BC to transfer control of the bus to a remote terminal device. Acceptance/denial of control resides with the RT and if accepted, the RT is promoted to the sole BC on the bus.

Transmit Status Word is utilized by the BC to determine if the RT received the previous command properly.

Initiate Self Test initiates the RT to perform its Built in Test (BIT). Usually followed with a Transmit BIT word mode command to determine the results of the test. The degree of testing available from the RT is a function of its design and capability.

4.3.3.5.1.7.5 Transmitter Shutdown

This command (to only be used with dual redundant bus systems) shall cause the RT to disable the transmitter associated with the redundant bus. The RT shall not comply with a command to shut down a transmitter on the bus from which this command is received. In all cases, the RT shall respond with a status word as specified in 4.3.3.5.3 after this command.

4.3.3.5.1.7.6 Override Transmitter Shutdown

This command (to only be used with dual redundant bus system) shall cause the RT to enable a transmitter which was previously disabled. The RT shall not comply with a command to enable a transmitter on the bus from which this command is received. In all cases, the RT shall respond with a status word as specified in 4.3.3.5.3 after this command.

4.3.3.5.1.7.7 Inhibit Terminal Flag (T/F) bit

This command shall cause the RT to set the T/F bit in the status word specified in 4.3.3.5.3 to logic zero until otherwise commanded. The RT shall transmit the status word as specified in 4.3.3.5.3.

4.3.3.5.1.7.8 Override Inhibit T/F bit

This command shall cause the RT to override the inhibit T/F bit specified in 4.3.3.5.1.7.7. The RT shall transmit the status word as specified in 4.3.3.5.3.

4.3.3.5.1.7.9 Reset Remote Terminal

This command shall be used to reset the RT to a power up initialized state. The RT shall first transmit its status word, and then reset.

Specification

Interpretation

Transmitter Shutdown and Override Transmitter Shutdown are used only in a dual redundant bus system to shut down and restart an RT. The Override command must be issued on the standby or backup bus.

The Inhibit Terminal Flag, when set, indicates a “no fail” condition, regardless of the actual state of the terminal flag. The BC can use this command to eliminate ongoing error messages from an RT that may be sending extraneous or erroneous messages.

Override Inhibit Terminal Flag allows the RT to report its actual operating condition.

4.3.3.5.1.7.10 Reserved Mode Codes (01001 to 01111)

These mode codes are reserved for future use and shall not be used.

4.3.3.5.1.7.11 Transmit Vector Word

This command shall cause the RT to transmit a status word as specified in 4.3.3.5.3 and a data word containing service request information.

4.3.3.5.1.7.12 Synchronize (with data word)

The RT shall receive a command word followed by a data word as specified in 4.3.3.5.2. The data word shall contain synchronization information for the RT. After receiving the command and data word, the RT shall transmit the status word as specified in 4.3.3.5.3.

4.3.3.5.1.7.13 Transmit Last Command Word

This command shall cause the RT to transmit its status word as specified in 4.3.3.5.3 followed by a single data word which contains bits 4-19 of the last command word, excluding a transmit last command word mode code received by the RT. This mode command shall not alter the state of the RT's status word



Specification

Interpretation

Transmit Vector Word is related to the Service Request bit in the status word and determines specific service requested by the RT.

Synchronization provides the BC a method of establishing a common timing structure with RTs. The synchronization can be done with the Command word itself, or with more detail through an attached Data word.

Transmit Last Command Word is sent by the BC to determine the last valid command received by the RT, prior to this mode command. This command is used to determine if errors exist and assist in data recovery. This mode code does not change the contents of the last command or status word. An RT resends the previous status word with a data word containing the previous valid command word received.

4.3.3.5.1.7.14 Transmit Built-in-Test (BIT) Word

This command shall cause the RT to transmit its status word as specified in 4.3.3.5.3 followed by a single data word containing the RT BIT data. This function is intended to supplement the available bits in the status word when the RT hardware is sufficiently complex to warrant its use. The data word, containing the RT BIT data, shall not be altered by the reception of a transmit last command or a transmit status word mode code. This function shall not be used to convey BIT data from the associated subsystems(s).

4.3.3.5.1.7.15 Selected Transmitter Shutdown

This command shall cause the RT to disable the transmitter associated with a specified redundant data bus. The command is designed for use with systems employing more than two redundant buses. The transmitter that is to be disabled shall be identified in the data word following the command word in the format as specified in 4.3.3.5.2. The RT shall not comply with a command to shut down a transmitter on the bus from which this command is received. In all cases, the RT shall respond with a status word as specified in 4.3.3.5.3.

4.3.3.5.1.7.16 Override Selected Transmitter Shutdown

This command shall cause the RT to enable a transmitter which was previously disabled. The command is designed for use with systems employing more than two redundant buses. The transmitter that is to be enabled shall be identified in the data word following the command word in the format as specified in 4.3.3.5.2. The RT shall not comply with a command to enable a transmitter on the bus from which this command is received. In all cases, the RT shall respond with a status word as specified in 4.3.3.5.3.

4.3.3.5.1.7.17 Reserved Mode Codes (10110 to 11111)

These mode codes are reserved for future use and shall not be used.



Transmit BIT Word provides the BC with the selected RT's Built in test results. This command allows error recovery procedures without changing the error data recorded in the word.

4.3.3.5.2 Data Word

A data word shall be comprised of a sync waveform, data bits, and a parity bit (see Figure 3-3).

4.3.3.5.2.1 Sync

The data sync waveform shall be an invalid Manchester waveform as shown on Figure 3-5. The width shall be three bit times, with the waveform being negative for the first one and one-half bit times, and then positive for the following one and one-half bit times. Note that if the bits preceding and following the sync are logic ones, then the apparent width of the sync waveform will be increased to four bit times.

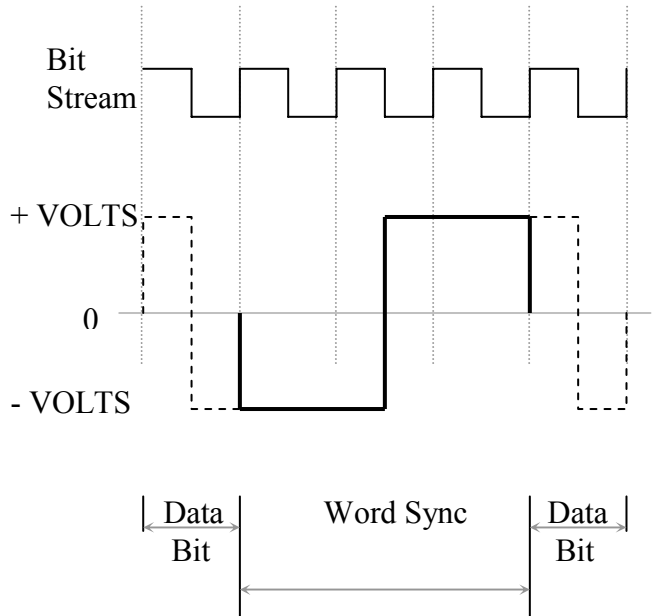

Figure 3-5 – Data Sync

4.3.3.5.2.2 Data

The sixteen bits following the sync shall be utilized for data transmission as specified in 4.3.2.

4.3.3.5.2.3 Parity

The last bit shall be utilized for parity as specified in 4.3.3.5.1.6.



Data words contain the actual information and can be transmitted by a BC or an RT

Data words are transmitted by a BC, or by an RT in response to a BC request. Data words may also be sent between two RTs. MIL-STD-1553B allows a maximum of 32 data words to be sent in a packet with a command word. Data words contain the most information of the three words and are the least structured words in MIL-STD-1553B.

The Data word sync is unique. The command and status word sync pattern is the same.

4.3.3.5.3 Status Word

A status word shall be comprised of a sync waveform, RT address, message error bit, instrumentation bit, service request bit, three reserved bits, broadcast command received bit, busy bit, subsystem flag bit, dynamic bus control acceptance bit, terminal flag bit, and a parity bit. For optional broadcast operation, transmission of the status word shall be suppressed as specified in 4.3.3.6.7.

4.3.3.5.3.1 Sync

The status sync waveform shall be as specified in 4.3.3.5.1.1.

4.3.3.5.3.2 RT Address

The next five bits following the sync shall contain the address of the RT which is transmitting the status word as defined in 4.3.3.5.1.2.

Specification

Interpretation

Status words are transmitted by a remote terminal in response to an error free, nonbroadcast command. Status words relay conditional information about the RT, errors detected by the RT in the command or data sent from the BC, or an RT request for service. Status words are only transmitted by RTs after receiving a command from a BC.

The purpose of transmitting the RT address in a status response allows the BC to verify the correct RT is responding and prevents any other RT from mistaking the status response as a command (the sync pattern for both is the same) due to different addresses.

4.3.3.5.3.3 Message Error Bit

The status word bit at bit time nine (see Figure 3-3) shall be utilized to indicate that one or more of the data words associated with the preceding received command word from the bus controller has failed to pass the RT's validity test as specified in 4.4.1.1. This bit shall also be set under the conditions specified in 4.4.1.2, 4.4.3.4, and 4.4.3.6. A logic one shall indicate the presence of a message error, and a logic zero shall show its absence. All RTs shall implement the message error bit.

4.3.3.5.3.4 Instrumentation Bit

The status word at bit time ten (see Figure 3-3) shall be reserved for the instrumentation bit and shall always be a logic zero. This bit is intended to be used in conjunction with a logic one in bit time ten of the command word to distinguish between a command word and a status word. The use of the instrumentation bit is optional.



Specification

Interpretation

The Message Error Bit is used by the RT to indicate an error in the command or data word transmission from the BC. The Message Error bit is set to a logic 1 when any of the following conditions occur:

- a. *A data word received from the BC contains an error*
- b. *A gap is detected between data words*
- c. *The RT does not recognize a received command*
- d. *The wrong number of data words is received by the RT.*

If the RT detects an error, the Message Error bit is set, but the status word is not sent. The BC must send a "Transmit Last Status" mode command to determine the reason for no response. After receiving this mode command, the RT transmits the Status word with the Message Error bit set. The Message Error bit remains set to a logic 1 until a new valid command, other than "Transmit Last Status", is received by this RT.

The Instrumentation bit is used to differentiate between command and status words.

4.3.3.5.3.5 Service Request Bit

The status word bit at bit time eleven (see Figure 3-3) shall be reserved for the service request bit. The use of this bit is optional. This bit when used, shall indicate the need for the bus controller to take specific predefined actions relative to either the RT or associated subsystems. Multiple subsystems, interfaced to a single RT, which individually requires a service request signal shall logically OR their individual signals into the single status word bit. In the event this logical OR is performed, then the designer must make provisions in a separate data word to identify the specific requesting subsystems. The service request bit is intended to be used only to trigger data transfer operations which take place on an exception rather than periodic basis. A logic one shall indicate the presence of a service request, and a logic zero its absence. If this function is not implemented, the bit shall be set to zero.

4.3.3.5.3.6 Reserved Status Bits

The status word bits at bit times twelve through fourteen are reserved for future use and shall not be used. These bits shall be set to a logic zero.

4.3.3.5.3.7 Broadcast Command Received Bit

The status word at bit time fifteen shall be set to a logic one to indicate that the preceding valid command word was a broadcast command and a logic zero shall show it was not a broadcast command. If the broadcast command option is not used, this bit shall be set to a logic zero.



The Service Request bit indicates the RT requires service. This bit can also be set to direct the BC to initiate a predefined data transfer or mode command.

The Broadcast Command Received bit indicates the RT received a valid broadcast command. This bit is set to a logic 1 when a broadcast message is received and remains set until the RT transmits the status word or receives a valid, non-broadcast command. The BC can use this bit to determine if a broadcast command was received error free by requesting the status word to be sent. The use of this bit is optional and is cleared to a logic 0 if not utilized.

4.3.3.5.3.8 Busy Bit

The status word bit at bit time sixteen (see Figure 3-3) shall be reserved for the busy bit. The use of this bit is optional. This bit, when used, shall indicate that the RT or subsystem is unable to move data to or from the subsystem in compliance with the bus controller's command. A logic one shall indicate the presence of a busy condition, and a logic zero its absence. In the event the busy bit is set in response to a transmit command, then the RT shall transmit its status word only. If this function is not implemented, the bit shall be set to logic zero.

4.3.3.5.3.9 Subsystem Flag Bit

The status word bit at bit time seventeen (see Figure 3-3) shall be reserved for the subsystem flag bit. The use of this bit is optional. This bit, when used, shall flag a subsystem fault condition, and alert the bus controller to potentially invalid data. Multiple subsystems, interfaced to a single RT, which individually require a subsystem flag bit signal shall logically OR their individual signals into the single status word bit. In the event this logical OR is performed, then the designer must make provisions in a separate data word to identify the specific reporting subsystem. A logic one shall indicate the presence of the flag, and a logic zero its absence. If not used, this bit shall be set to logic zero.

4.3.3.5.3.10 Dynamic Bus Control Acceptance Bit

The status word bit at bit time eighteen (see Figure 3-3) shall be reserved for the acceptance of dynamic bus control. This bit shall be used if the RT implements the optional dynamic bus control function. This bit, when used, shall indicate acceptance or rejection of a dynamic bus control offer as specified in 4.3.3.5.1.7.1. A logic one shall indicate acceptance of control, and a logic zero shall indicate rejection of control. If not used, this bit shall be set to logic zero.



Specification



Interpretation

The Busy bit indicates the RT is unable to transfer data. Set to a logic 1 when the RT is unable to move data to or from the terminal device in response to a BC command, this bit stays set as long as the busy condition exists. The use of this bit is optional and is cleared to a logic 0 if not utilized.

The Subsystem Flag bit is used by the RT to alert the BC that a subsystem fault exists and the data transmitted may be invalid. Set to a logic 1 to indicate a fault condition, the bit remains set until the subsystem fault is resolved. The use of this bit is optional and is cleared to a logic 0 if not utilized.

The Dynamic Bus Control Acceptance bit is used by the RT to indicate to the BC that this RT has accepted the dynamic Bus Control command. This immediately transfers control of the bus to this RT, which now acts as the backup bus controller. If the RT rejects dynamic bus control, the bit is reset to a logic 0. Upon transmission of the status word, the bit is cleared. The use of this bit is optional and is cleared to a logic 0 if not utilized.

4.3.3.5.3.11 Terminal Flag Bit

The status word bit at bit time nineteen (see Figure 3-3) shall be reserved for the terminal flag function. The use of this bit is optional. This bit, when used, shall flag a RT fault condition. A logic one shall indicate the presence of the flag, and a logic zero, its absence. If not used, this bit shall be set to logic zero.

4.3.3.5.3.12 Parity Bit

The least significant bit in the status word shall be utilized for parity as specified in 4.3.3.5.1.6.

4.3.3.5.4 Status Word Reset

The status word bit, with the exception of the address, shall be set to logic zero after a valid command word is received by the RT with the exception as specified in 4.3.3.5.1.7. If the condition which caused bits in the status word to be set (e.g., terminal flag) continue after the bits are reset to logic zero, then the affected status word bit shall be again set, and then transmitted on the bus as required.



The Terminal Flag bit indicates a fault in the RT itself. The bit is set to a logic 1 until the fault is resolved. The use of this bit is optional and is cleared to a logic 0 if not utilized.

The Parity bit is used on each word to identify bit errors during transmission. This odd parity check will detect an odd number of bit errors occurring in a word.

Status Word Reset is a command issued to reset the Status Code field of the status word. This prevents a condition being reported longer than it actually exists. Receiving a valid message or mode command will reset the RT's status word, except Transmit Status Word and Transmit Last Command Word. Neither of these mode codes will change the bits in the Status Code field of the last valid command word.

4.3.3.6 Message Formats

The messages transmitted on the data bus shall be in accordance with the formats on Figure 3-6 and Figure 3-7. The maximum and minimum response times shall be as stated in 4.3.3.7 and 4.3.3.8. No message formats, other than those defined herein, shall be used on the bus.



Specification

Interpretation

MIL-STD-1553B defines 10 types of messages to be transmitted over the bus as shown in Figures 3-6 and 3-7. Each message is composed of control words (command and status) and data words, and is always initiated with a BC command.

Normal command/response communications, as shown in Figure 3-6, start with a command from the BC, transmitted to a selected RT address. The RT receives or transmits data - depending on the BC command - and transmits a status word response if the transmission is valid and received error-free. The BC can also initiate an Information transfer between two RTs by issuing one a Transmit command and the other, a Receive.

Mode commands, as shown in Figures 3-6 and 3-7, are used in terminal control and systems checks. Mode commands may or may not involve the transfer of a data word.

Broadcast commands, as shown in Figure 3-7, are commands sent to multiple RTs at once. Although restricted under Notice 1, Notice 2 allows broadcast command transmissions but only the broadcast mode commands shown in Table 3-I. The RT is responsible for distinguishing between broadcast and non-broadcast command messages. An RT address of 11111 (31) indicates a broadcast message.

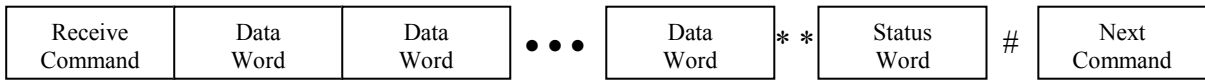

Controller to RT Transfer

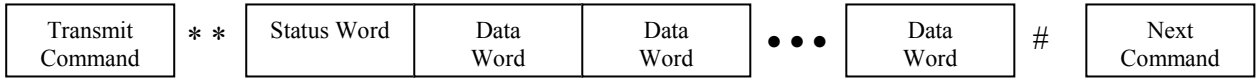

RT to Controller Transfer

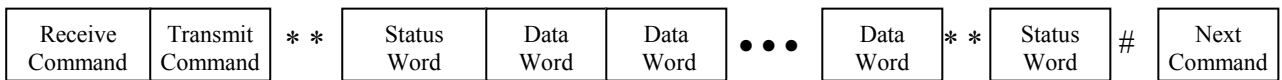

RT to RT Transfer

Note:

- # Intermessage Gap
- * * Response Time

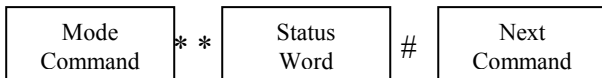

Mode Command without Data Word

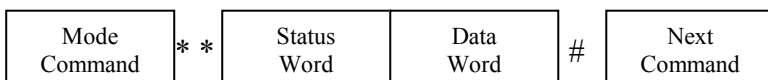

Mode Command with Data Word (Transmit)

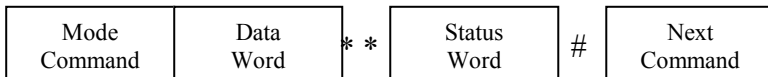

Mode Command with Data Word (Receive)

Figure 3-6 – Information Transfer Formats

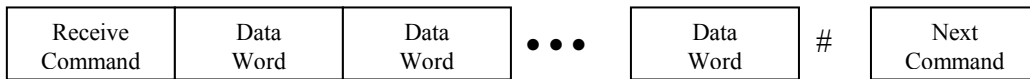

Controller to RT(s) Broadcast

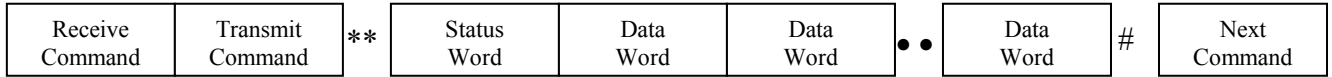

RT to RT(s) Broadcast



Mode Command without Data Word

Note:

- # Intermessage Gap
- ** Response Time

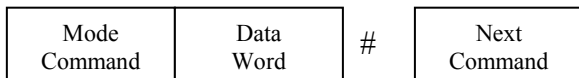

Mode Command with Data Word (Receive)

Figure 3-7 – Broadcast Information Transfer Formats

4.3.3.6.1 Bus Controller to Remote Terminal Transfers

The bus controller shall issue a receive command followed by the specified number of data words. The RT shall, after message validation, transmit a status word back to the controller. The command and data words shall be transmitted in a contiguous fashion with no interword gaps.

4.3.3.6.2 Remote Terminal to Bus Controller Transfers

The bus controller shall issue a transmit command to the RT. The RT shall, after command word validation, transmit a status word back to the bus controller, followed by the specified number of data words. The status and data words shall be transmitted in a contiguous fashion with no interword gaps

A diagram consisting of a horizontal line with a house-shaped arrow pointing upwards from the center. The word 'Specification' is written inside the arrow.

Specification

A diagram consisting of a horizontal line with a house-shaped arrow pointing downwards from the center. The word 'Interpretation' is written inside the arrow.

Interpretation

BC-RT

In this most common informational transfer, the BC sends data to an RT. The message begins with a command word with the T/R bit reset to a logic 0 to indicate the RT is to receive data. The value set in the Data Word Count/Mode Code field of the command word tells the RT how many data words will be transmitted after the command word. There is no gap between the command word and the data word, or between data words themselves.

The receiving RT validates the incoming message and, if the message is valid and legal, responds with a status word acknowledging message receipt.

RT-BC

This informational exchange involves the BC requesting an RT to send data back. The message begins with a command word with the T/R bit set to a logic 1 to initiate the RT to transmit data. The value set in the Data Word Count/Mode Code field of the command word indicates the number of data words the RT is to transmit.

4.3.3.6.3 Remote Terminal to Remote Terminal Transfers

The bus controller shall issue a receive command to RT A followed contiguously by a transmit command to RT B. RT B shall, after command validation, transmit a status word followed by the specified number of data words. The status and data words shall be transmitted in a contiguous fashion with no gap. At the conclusion of the data transmission by RT B, RT A shall transmit a status word within the specified time period.



Specification

Interpretation

RT-RT

This exchange of data is again initiated by the BC, but involves a transfer of information between two RTs. The BC directs this transfer by sending two back-to-back commands.

First, a Receive command is sent to the receiving RT, with the T/R bit reset to a logic 0 for Receive, and the Data Word Count/Mode Code field indicating the number of words to accept.

Second, without any gap between commands, a Transmit command is sent to the transmitting RT with the T/R bit set to a logic 1. The Data Word Count/Mode Code field indicates the number of words to transmit.

The Address field in the Receive and Transmit command words contains the address of the receiving and transmitting RTs and should always be different. The Data Word Count/Mode Code fields in both words have to be the same for the transfer to be successful.

The transmitting RT responds to the Transmit command by sending a status word to the Receiving RT with the appropriate number of data words. The receiving RT responds with a status word acknowledging receipt of the valid, error-free message.

4.3.3.6.4 Mode Command without Data Word

The bus controller shall issue a transmit command to the RT using a mode code specified in Table 3-I. The RT shall, after command word validation, transmit a status word.

4.3.3.6.5 Mode Command with Data Word (Transmit)

The bus controller shall issue a transmit command to the RT using a mode code specified in Table 3-I. The RT shall, after command word validation, transmit a status word followed by one data word. The status word and data word shall be transmitted in a contiguous fashion with no gap.

4.3.3.6.6 Mode Command with Data Word (Receive)

The bus controller shall issue a receive command to the RT using a mode code specified in Table 3-I, followed by one data word. The command word and data word shall be transmitted in a contiguous fashion with no gap. The RT shall, after command and data word validation, transmit a status word back to the controller.

Specification

Interpretation

Mode command messages are sent from the BC to an RT to control its operation, check its operating status or perform general data bus management. For a command from the BC to be recognized by the RTs as a mode command, the Command Word Subaddress/Mode field in the command word has to be set to 0 (00000) or 31 (11111). With that designation, the Data Word Count/Mode Code field now contains the mode code for the command to be implemented. Mode codes can be sent without requesting an RT to receive or transmit a single data word, or the command may not involve any data words at all.

Mode Command without Data Word

The BC issues a command to an RT that doesn't involve any associated data words. This message contains a single command word from the BC, with the T/R bit set to a logic 1, indicating the RT is to transmit. Mode commands are received by the RT, validated, and responded to by sending back a status word. Mode commands without data words involve only two words, the mode command word from the BC and the status word reply from the RT.

Mode Command with Data Word – Transmit

Certain mode commands require the RT to include a data word with the status word response. The mode command word has the T/R bit set to a logic 1, indicating the RT is to Transmit data. Depending upon the mode code set in the command word's Data Word Count/Mode Code field, the RT responds with a status word and one data word.

Mode Command with Data Word – Receive

Some mode commands require the RT to receive a single data word. This message type contains a command word from the BC with the T/R bit reset to a logic 0 to indicate the RT is to Receive the included single data word. After receiving and validating the message, the Receiving RT responds with a status word of acknowledgement.

4.3.3.6.7 Optional Broadcast Command

See 10.6 for additional information on the use of the broadcast command.

4.3.3.6.7.1 Bus Controller to Remote Terminal(s) Transfer (Broadcast)

The bus controller shall issue a receive command word with 11111 (31) in the RT address field followed by the specified number of data words. The command word and data words shall be transmitted in a contiguous fashion with no gap. The RT(s) with the broadcast option shall after message validation, set the broadcast command received bit in the status word as specified in 4.3.3.5.3.7 and shall not transmit the status word.

4.3.3.6.7.2 Remote Terminal to Remote Terminal(s) Transfer (Broadcast)

The bus controller shall issue a receive command word with 11111 (31) in the RT address field followed by a transmit command to RT A using the RT's address. RT A shall, after command word validation, transmit a status word followed by the specified number of data words. The status and data words shall be transmitted in a contiguous fashion with no gap. The RT(s) with the broadcast option, excluding RT A, shall after message validation, set the broadcast received bit in the status word as specified in 4.3.3.5.3.7 and shall not transmit the status word.



Specification

Interpretation

Section 10.6 warns of using broadcast commands, as shown in Figure 3-7, due to the inability of the BC to verify command receipt by the RT. Since multiple RTs are being sent the command simultaneously, the status word reply normally associated with command/response protocol is suppressed to avoid data collisions on the bus. Notice 1 of MIL-STD-1553B disallowed the use of all broadcast messages, Notice 2 allowed broadcast messages only in the mode command format.

4.3.3.6.7.3 Mode Command without Data Word (Broadcast)

The bus controller shall issue a transmit command word with 11111 (31) in the RT address field, and a mode code specified in Table 3-I. The RT(s) with the broadcast option shall after command word validation, set the broadcast received bit in the status word as specified in 4.3.3.5.3.7 and shall not transmit the status word.

4.3.3.6.7.4 Mode Command with Data Word (Broadcast)

The bus controller shall issue a receive command word with 11111 (31) in the RT address field and a mode code specified in Table 3-I, followed by one data word. The command word and data word shall be transmitted in a contiguous fashion with no gap. The RT(s) with the broadcast option shall, after message validation, set the broadcast received bit in the status word as specified in 4.3.3.5.3.7. and shall not transmit the status word.

Specification

Interpretation

Mode commands are used to control operation and check status of RTs. For a command from the BC to be recognized by the RTs as a Mode Command, the Command Word Subaddress/Mode field in the Command word has to be set to 0 (00000) or 31 (11111). With that designation, the Data Word Count/Mode Code field now contains the Mode Code for the command to be implemented.

Mode Codes can be sent with a single Data word, or the command may not involve any data words at all.

Mode Command without Data Word (Broadcast)

The BC issues a command to RT(s) that doesn't involve any associated Data words. This message contains a single command word from the BC. Mode commands are received by the RT, validated, and the broadcast received bit in the status word is set, but the transmission of the status word is suppressed. Broadcast mode commands without data words involve only one word. In order for the BC to verify receipt, it must poll each RT and issue a Transmit Status Word command.

Mode Command with Data Word (Broadcast)

Some broadcast mode commands require the RT to receive a single data word. This message type contains a command word from the BC with the T/R bit reset to a logic 0 to indicate the RT is to receive the included single data word. After receiving and validating the message, the Receiving RT sets the Broadcast Received bit in the status word reply but suppresses the transmission.

4.3.3.7 Intermessage Gap

The bus controller shall provide a minimum gap time of 4.0 microseconds (μs) between messages as shown on Figure 3-6 and Figure 3-7. This time period, shown as T on Figure 3-8, is measured at point A of the bus controller as shown on Figure 3-9 or Figure 3-10. The time is measured from the mid-bit zero crossing of the last bit of the preceding message to mid-zero crossing of the next command word sync.

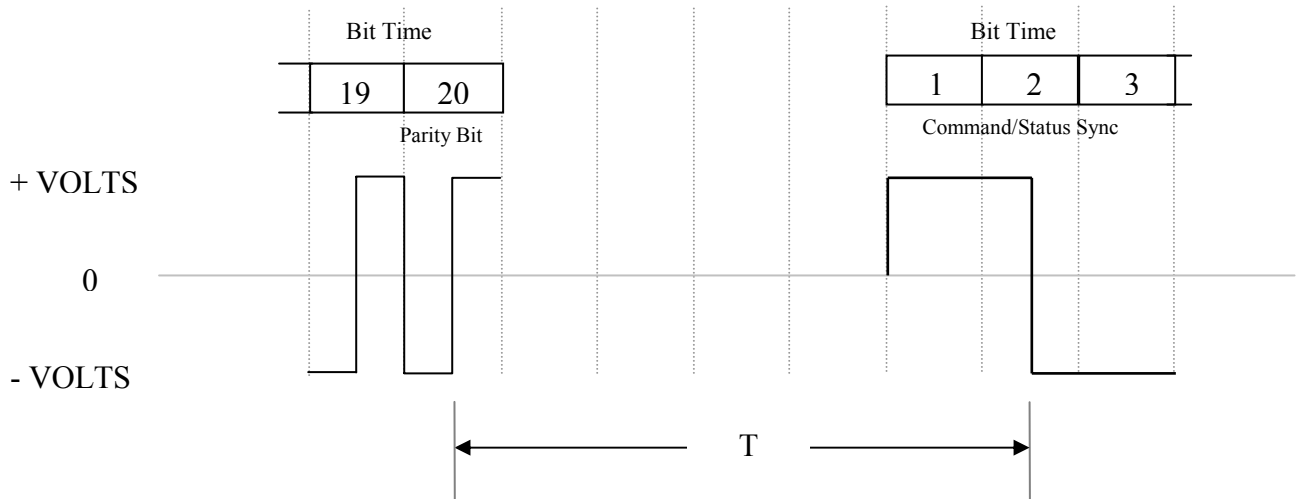

Figure 3-8 – Intermessage Gap and Response Time

Specification

Interpretation

The time gap between messages is defined as the Intermessage Gap. MIL-STD-1553B sets this interval to a minimum of 4 μs between message transmissions.

RTs are required to respond to commands addressed to them, that are valid and error free, within a specific time period, the RT Response Time. The RT Response Time set by MIL-STD-1553B requires a response from the RT within 4 to 12 μs . If the BC does not reply within this window, the BC sends a “Transmit Last Status” command in an attempt to resolve the error. RTs will not send a status word in response to a command message with errors. Any terminal requesting a response must wait a minimum of 14 μs for status word response. This time can be extended for longer periods by RT design.

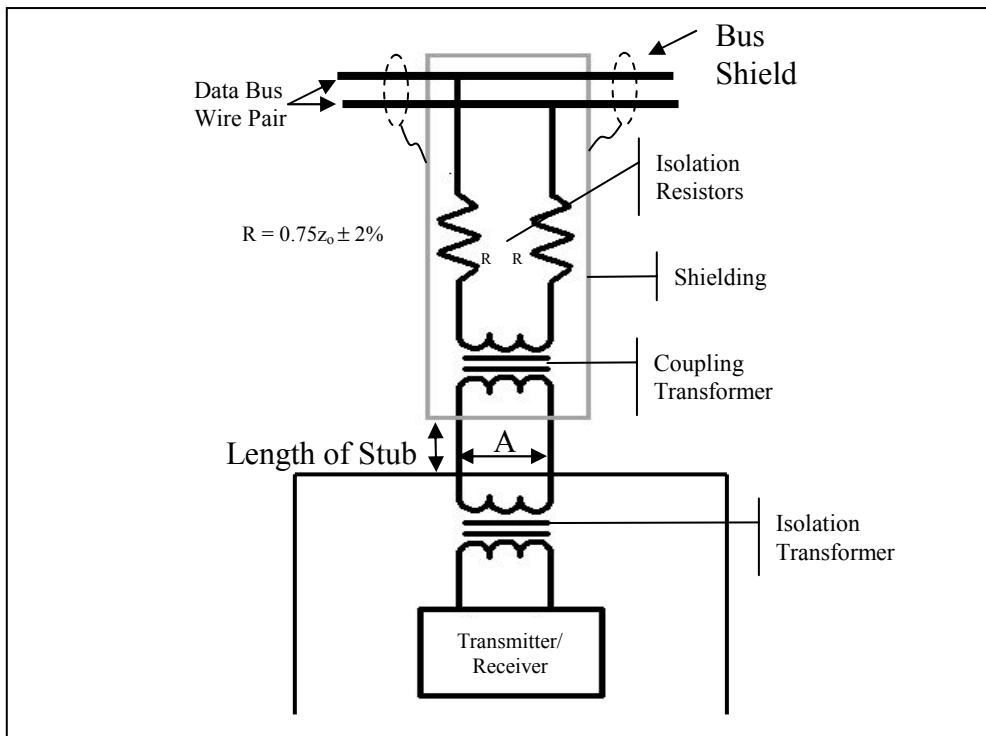

Figure 3-9 – Data Bus Interface Using Transformer Coupling

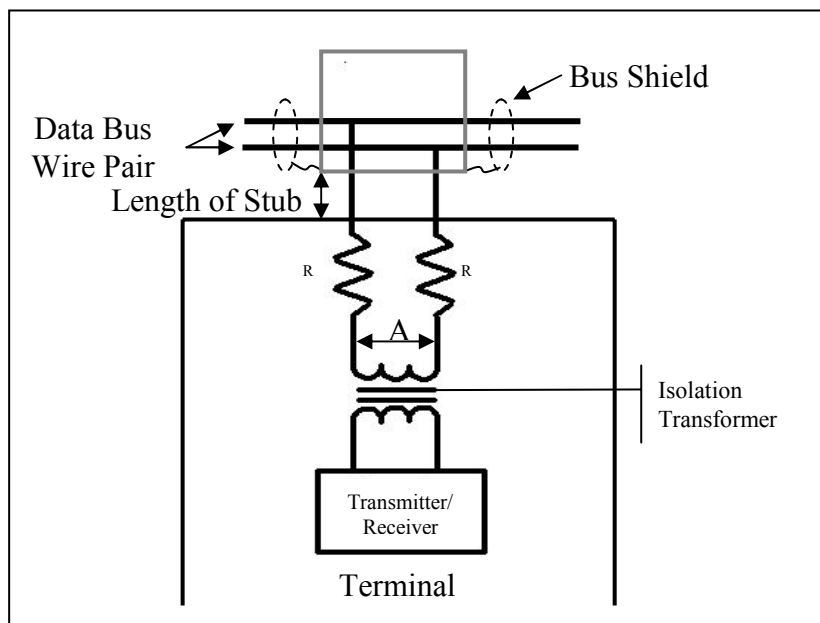

Figure 3-10 – Data Base Interface Using Direct Coupling

4.3.3.8 Response Time

The RT shall respond, in accordance with 4.3.3.6, to a valid command word within the time period of 4.0 to 12.0 μ s. This time period, shown as T on Figure 3-8, is measured at point A of the RT as shown on Figure 3-9 or Figure 3-10. The time is measured from the mid-bit zero crossing of the last word as specified in 4.3.3.6 and as shown on Figure 3-6 and Figure 3-7 to the mid-zero crossing of the status word sync.

4.3.3.9 Minimum No-Response Time-out

The minimum time that a terminal shall wait before considering that a response as specified in 4.3.3.8 has not occurred shall be 14.0 μ s. The time is measured from the mid-bit zero crossing of the last bit of the last word to the mid-zero crossing of the expected status word sync at point A of the terminal as shown on Figure 3-9 or Figure 3-10.

4.4 Terminal Operation

4.4.1 Common Operation

Terminals shall have common operation capabilities as specified in the following paragraphs.

4.4.1.1 Word Validation

The terminal shall insure that each word conforms to the following minimum criteria:

- a. The word begins with a valid sync field.
- b. The bits are in a valid Manchester II code.
- c. The information field has 16 bits plus parity.
- d. The word parity is odd.

When a word fails to conform to the preceding criteria, the word shall be considered invalid.

4.4.1.2 Transmission Continuity

The terminal shall verify that the message is contiguous as defined in 4.3.3.6. Improperly timed data syncs shall be considered a message error.



Specification

Interpretation

Each word received by a terminal device on the bus must be validated by conforming to the following MIL-STD-1553B requirements listed above. Failure to meet all requirements constitutes an invalid word.

The BC is required to validate status and data words sent from RTs and RTs are required to validate command and data words transmitted by the BC.

4.4.1.3 Terminal Fail-Safe

The terminal shall contain a hardware implemented time-out to preclude a signal transmission of greater than 800.0 μ s. This hardware shall not preclude a correct transmission in response to a command. Reset of this time-out function shall be performed by the reception of a valid command on the bus on which the time-out has occurred.

4.4.2 Bus Controller Operation

A terminal operating as a bus controller shall be responsible for sending data bus commands, participating in data transfers, receiving status responses, and monitoring system status as defined in this standard. The bus controller function may be embodied as either a stand-alone terminal, whose sole function is to control the data bus(s), or contained within a subsystem. Only one terminal shall be in active control of a data bus at any one time.

4.4.3 Remote Terminal

4.4.3.1 Operation

A remote terminal (RT) shall operate in response to valid commands received from the bus controller. The RT shall accept a command word as valid when the command word meets the criteria of 4.4.1.1, and the command word contains a terminal address which matches the RT address of an address of 31 (11111), if the RT has the broadcast option. No combination of RT address bits, T/R bit, subaddress/mode bits, and data word count/mode code bits of a command word shall result in invalid transmissions by the RT. Subsequent valid commands shall be properly responded to by the RT.**

Specification

Interpretation

There is to be no time gap, contiguous transmission, between a command or status word, and any associated data words being transmitted with it. Likewise, multiple data words being transmitted have no time gap between them - contiguous transmission.

The main function of the bus controller (BC) is to provide data flow control for all transmissions on the bus. In addition to initiating all data transfers, the BC must transmit, receive and coordinate the transfer of information on the data bus. All information is communicated in command/response mode.

The remote terminal (RT) is a device designed to interface various subsystems with the 1553 data bus. The interface device may be embedded within the subsystem itself, or be an external interface to tie a non-1553 compatible device to the bus. As a function of the interface requirement, the RT receives and decodes commands from the BC, detects any errors and reacts to those errors. The RT must be able to properly handle both protocol errors (missing data, extra words, etc) and electrical errors (waveform distortion, rise time violations, etc). RTs are the largest segment of bus components.

*** Last two sentences of this paragraph were added with Notice 2.*

4.4.3.2 Superseding Valid Commands

The RT shall be capable of receiving a command word on the data bus after the minimum intermessage gap time as specified in 4.3.3.7 has been exceeded, when the RT is not in the time period T as specified in 4.3.3.8 prior to the transmission of a status word, and when it is not transmitting on that data bus. A second valid command word sent to an RT shall take precedence over the previous command. The RT shall respond to the second valid command as specified in 4.3.3.8.

4.4.3.3 Invalid Commands

A remote terminal shall not respond to a command word which fails to meet the criteria specified in 4.4.3.1.



An RT must be capable of receiving new commands while working on one already received. While processing on a command, and after the required intermessage gap, an RT receives a new command. The RT must terminate the first command and perform the second. The same is true if a new command comes in on the secondary bus.

An Invalid Command (or message) on a MIL-STD-1553B bus occurs when any of the following conditions are detected:

- a. *The message contains an Invalid word*
- b. *Non-contiguous words (a gap exists between command/status words and data words, or between data words)*
- c. *Word Count errors.*

Validation errors in the data portion of a message prompts the RT to create a status word reply with the Message Error bit set to a logic 1, but the transmission of the status word is suppressed. The BC could then send a “Transmit Last Status Word” Mode Code to attempt to resolve the error.

If the RT detects errors in the command word of a message, the RT ignores the entire message – no error flags are set. Since the error was in the command word, there is no assurance that the command was directed to this RT.

The BC must likewise validate status and data words from an RT and if the BC cannot validate a word, the message is ignored.

4.4.3.4 Illegal Commands

An illegal command is a valid command as specified in 4.4.3.1, where the bits in the subaddress/mode field, data word count/mode code field, and the T/R bit indicate a mode command, subaddress, or word count that has not been implemented in the RT. It is the responsibility of the bus controller to assure that no illegal commands are sent out. The RT designer has the option of monitoring for illegal commands. If an RT that is designed with this option detects an illegal command and the proper number of contiguous valid data words as specified by the illegal command word, it shall respond with a status word only, setting the message error bit, and not use the information received.

4.4.3.5 Valid Data Reception

The remote terminal shall respond with a status word when a valid command word and the proper number of contiguous data words are received, or a single valid word associated with a mode code is received. Each data word shall meet the criteria specified in 4.4.1.1.

4.4.3.6 Invalid Data Reception

Any data word(s) associated with a valid receive command that does not meet the criteria specified in 4.4.1.1 and 4.4.1.2 or an error in the data word count shall cause the remote terminal to set the message error bit in the status word to a logic one and suppress the transmission of the status word. If a message error has occurred, then the entire message shall be considered invalid.



Illegal Commands received by an RT exist under the following conditions:

- a. *An error exists in the T/R bit*
- b. *The Subaddress/Mode Code field is an unassigned address*
- c. *The Subaddress/Mode Code field is an unimplemented mode code*

Command words must be valid words before being considered illegal. That is, they must first conform to Word Validation (proper sync, encoding and parity) before an Illegal condition can be analyzed. If a command word does not meet Word Validation requirements, the command is ignored.

Illegal commands can be dealt with differently depending on the Illegal Command Detection capability of the RT. Typically, the Message Error bit is set in the RT's status word, with the transmission suppressed. Anytime an RT receives a valid command with data words that are invalid or non-contiguous, the RT creates a status word reply with the Message Error bit set to a logic 1, but the transmission of the status word is suppressed. The BC could then send a "Transmit Last Status Word" mode code to attempt to resolve the error.

If the RT detects errors in the command word of a message, the RT ignores the entire message – no error flags are set. Since the error was in the command word, there is no assurance that the command was directed to this RT.

4.4.4 Bus Monitor Operation

A terminal operation as a bus monitor shall receive bus traffic and extract selected information. While operating as a bus monitor, the terminal shall not respond to any message except one containing its own unique address if one is assigned. All information obtained while acting as a bus monitor shall be strictly used for off-line applications (e.g., flight test recording, maintenance recording or mission analysis) or to provide the back up bus controller sufficient information to take over as the bus controller.

4.5 Hardware Characteristics

4.5.1 Data Bus Characteristics

4.5.1.1 Cable

The cable used for the main bus and all stubs shall be a two conductor, twisted, shielded, jacketed cable. The wire-to-wire distributed capacitance shall not exceed 30.0 picofarads per foot. The cables shall be formed with not less than four twists per foot where a twist is defined as a 360 degree rotation of the wire pairs; and, the cable shield shall provide a minimum of 75% coverage.

4.5.1.2 Characteristic Impedance

The nominal characteristic impedance of the cable (Z_0) shall be within the range of 70.0 Ω to 85.0 Ω at a sinusoidal frequency of 1.0 megahertz (MHz).

4.5.1.3 Cable Attenuation

At the frequency of 4.5.1.2, the cable power loss shall not exceed 1.5 decibels (dB)/100 feet (ft).



The bus monitor (BM) listens to all messages on the bus and records selected activities. The BM is a passive device that collects data for real-time or post capture analysis. The BM can store all or portions of traffic on the bus, including electrical and protocol errors. BMs are primarily used for instrumentation and data bus testing.

The MIL-STD-1553B definition of a data bus is “a twisted-shielded pair transmission line made up of a main bus and a number of attached stubs”. Shielding limits signal interference from outside sources and the twisted pair maintains message integrity through noise canceling.

Cable Type	Twisted Shielded Pair
Capacitance	30 pF/ft _{max}
Cable Impedance	70-85 Ω at 1 MHz
Cable Attenuation	1.5 dB per 100 ft at 1 MHz _{max}
Twist Ratio	4 per foot _{min}
Shield Coverage	75% _{min}
Cable Termination	Cable Impedance \pm 2%

1553B Cable Characteristics

Notice 2 redefined Shield Coverage to 75% min.

4.5.1.4 Cable Termination

The two ends of the cable shall be terminated with a resistance, equal to the selected cable nominal characteristic impedance (Z_0) \pm 2.0%.

4.5.1.5 Cable Stub Requirements

The cable shall be coupled to the terminal as shown on Figure 3-9 or Figure 3-10. The use of long stubs is discouraged, and the length of a stub should be minimized. However, if installation requirements dictate, stub lengths exceeding those lengths specified in 4.5.1.5.1 and 4.5.1.5.2 are permissible.



See Table 2-I for a characteristics comparison between MIL-STD-1553A and 1553B.

Although MIL-STD-1553A set a 300 foot maximum bus length, MIL-STD-1553B does not specify a length. Multiple parameters of the bus design all factor into a reliable system. Stub loading effects, cable specifications, length and number of terminals all have a role in determining maximum bus length.

Terminating the main bus on either end minimizes any reflections from a cable mismatch and presents an infinite length bus. Adding stubs for terminal connections loads the bus and creates reflections. The amount of signal distortion and mismatch are a function of the impedance of the stub. A high stub impedance minimizes reflections, but a low enough stub impedance is necessary for adequate signal levels to reach the terminal. Signal-to-noise ratio and error rates are factors of proper coupling.

MIL-STD-1553B defines two methods of coupling terminals to the main bus – transformer coupling and direct coupling.

4.5.1.5.1 Transformer Coupled Stubs

The length of a transformer coupled stub should not exceed 20 feet. If a transformer coupled stub is used, then the following shall apply.

4.5.1.5.1.1 Coupling Transformer

A coupling transformer, as shown on Figure 3-9, shall be required. This transformer shall have a turns ratio of $1:1.41 \pm 3.0\%$, with the higher turns on the isolation resistor side of the stub.

4.5.1.5.1.1.1 Transformer Input Impedance

The open circuit impedance as seen at point B on Figure 3-11 shall be greater than 3000Ω over the frequency range of 75.0 kHz to 1.0 MHz, when measured with a 1.0 V root-mean-square (RMS) sine wave.

4.5.1.5.1.1.2 Transformer Waveform Integrity

The droop of the transformer using the test configuration shown on Figure 3-11 at point B, shall not exceed 20.0%. Overshoot and ringing as measured at point B shall be less than ± 1.0 V peak. For this test, R shall equal $360 \Omega \pm 5.0\%$ and the input A of Figure 3-11 shall be a 250 kHz square wave. 27.0 V peak-to-peak, with a rise and fall time no greater than 100 nanoseconds (ns).

4.5.1.5.1.1.3 Transformer Common Mode Rejection

The coupling transformer shall have a common mode rejection ratio greater than 45.0 dB at 1.0 MHz.



Figure 3-11 – Coupling Transformer

Specification

Interpretation

Transformer coupling is usually used with long stubs between 1 and 20 feet. In order to implement transformer coupling, a coupler box is required, separate from the terminal, inline with the main bus and includes the stub.

The transformers turns ratio provides the necessary impedance for terminal data reception and transmission. This type of coupling also provides isolation from the main bus in the event of terminal or stub fault, reduces signal distortion by increasing the effective stub impedance and prevents common mode noise on the bus from entering the stub.

4.5.1.5.1.2 Fault Isolation

An isolation resistor shall be placed in series with each connection to the data bus cable. This resistor shall have a value of $0.75 Z_0 \Omega \pm 2.0\%$, where Z_0 is the selected cable nominal characteristic impedance. The impedance placed across the data bus cable shall be no less than $1.5 Z_0 \Omega$ for any failure of the coupling transformer, cable stub, or terminal transmitter/receiver.

4.5.1.5.1.3 Cable Coupling

All coupling transformers and isolation resistors, as specified in 4.5.1.5.1.1 and 4.5.1.5.1.2, shall have continuous shielding which will provide a minimum of 75% coverage. The isolation resistors and coupling transformers shall be placed at minimum possible distance from the junction of the stub to the main bus.

4.5.1.5.1.4 Stub Voltage Requirements

Every data bus shall be designed such that all stubs at point A of Figure 3-9 shall have a peak-to-peak amplitude, line-to-line within the range of 1.0 and 14.0 V for a transmission by any terminal on the data bus. This shall include the maximum reduction of data bus signal amplitude in the event that one of the terminals has a fault which causes it to reflect a fault impedance specified in 4.5.1.5.1.2 on the data bus. This shall also include the worse case output voltage of the terminals as specified in 4.5.2.1.1.1 and 4.5.2.2.1.1.

4.5.1.5.2 Direct Coupled Stubs

The length of a direct coupled stub should not exceed 1 foot. Refer to 10.5 for comments concerning direct coupled stubs. If a direct coupled stub is used, then the following shall apply.

4.5.1.5.2.1 Fault Isolation

An isolation resistor shall be placed in series with each connection to the data bus cable. This resistor shall have a value of $55.0 \Omega \pm 2.0\%$. The isolation resistors shall be placed within the RT as shown on Figure 3-10.

4.5.1.5.2.2 Cable Coupling

All bus-stub junctions shall have continuous shielding which will provide a minimum of 75% coverage.

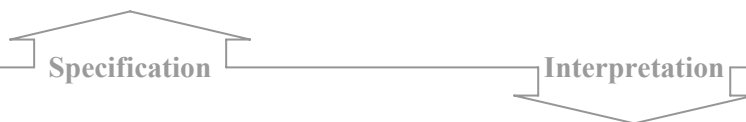

Direct coupled stubs are used for connections less than 1 foot.

With the isolation resistors located in the terminal device there is no need for a separate coupler box, reducing cost and size.

4.5.1.5.2.3 Stub Voltage Requirements

Every data bus shall be designed such that all stubs at point A of Figure 3-10 shall have a peak-to-peak amplitude, line-to-line within the range of 1.4 and 20.0 V for a transmission by any terminal on the data bus. This shall include the maximum reduction of data bus signal amplitude in the event that one of the terminals has a fault which causes it to reflect a fault impedance of 110 Ω on the data bus. This shall also include the worse case output voltage of the terminals as specified in 4.5.2.1.1.1 and 4.5.2.2.1.1.

4.5.1.5.3 Wiring and Cabling for EMC

For purposes of electromagnetic capability (EMC), the wiring and cabling provisions of MIL-E-6051 shall apply.



Section 10.5 of MIL-STD-1553 points out the preferred method of stubbing is to use transformer coupling to provide for direct current (DC) isolation, increased common mode protection, a doubling of effective stub impedance and fault isolation for the stub and terminal. Section 10.5 goes on to say direct coupled stubs should be avoided if at all possible.

4.5.2 Terminal Characteristics

4.5.2.1 Terminals with Transformer Coupled Stubs

4.5.2.1.1 Terminal Output Characteristics

The following characteristics shall be measured with R_L , as shown on Figure 3-12, equal to $70.0 \Omega \pm 2.0\%$.

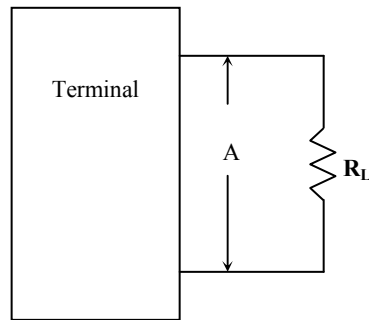

Figure 3-12 Terminal Input/Output Characteristics for Transformer Coupled Stubs and Direct Coupled Stubs

4.5.2.1.1.1 Output Levels

The terminal output voltage levels shall be measured using the test configuration shown on Figure 3-12. The terminal output voltage shall be within the range of 18.0 to 27.0 V, peak-to-peak, line-to-line, when measured at point A on Figure 3-12.

4.5.2.1.1.2 Output Waveform

The waveform, when measured at point A on Figure 3-12 shall have zero crossing deviations which are equal to, or less than, 25.0 ns from the ideal crossing point, measured with respect to the previous zero crossing (i.e., $.5 \pm .025 \mu\text{s}$, $1.0 \pm .025 \mu\text{s}$, $1.5 \pm .025 \mu\text{s}$, and $2.0 \pm .025 \mu\text{s}$). The rise and fall time of this waveform shall be from 100.0 to 300.0 ns when measured from levels of 10 to 90% of full waveform peak-to-peak, line-to-line, voltage as shown on Figure 3-13. Any distortion of the waveform including overshoot and ringing shall not exceed ± 900.0 millivolts (mV) peak, line-to-line, as measured at point A, Figure 3-12.

Specification

Interpretation

Output levels for transformer and direct coupled connections provide the same nominal bus voltage.

MIL-STD-1553A did not adequately define output waveform zero cross limits, output noise or symmetry. MIL-STD-1553B tightened the allowable deviations and set more realistic design limits.

4.5.2.1.1.3 Output Noise

Any noise transmitted when the terminal is receiving or has power removed, shall not exceed a value of 14.0 mV, RMS, line-to-line, as measured at point A, Figure 3-12.

4.5.2.1.1.4 Output Symmetry

From the time beginning 2.5 μ s after the mid-bit crossing of the parity bit of the last word transmitted by a terminal, the maximum voltage at point A of Figure 3-12 shall be no greater than \pm 250.0 millivolts (mV) peak, line-to-line. This shall be tested with the terminal transmitting the maximum number of words it is designed to transmit, up to 33. This test shall be run six times with each word in a contiguous block of words, having the same bit pattern. The six word contents that shall be used are 8000₁₆, 7FFF₁₆, 0000₁₆, FFFF₁₆, 5555₁₆, and AAAA₁₆. The output of the terminal shall be as specified in 4.5.2.1.1.1 and 4.5.2.1.1.2.

4.5.2.1.2 Terminal Input Characteristics

The following characteristics shall be measured independently.

4.5.2.1.2.1 Input Waveform Compatibility

The terminal shall be capable of receiving and operating with the incoming signals specified herein, and shall accept waveform varying from a square wave to a sine wave with a maximum zero crossing deviation from the ideal with respect to the previous zero crossing of \pm 150 ns, (i.e., 2.0 \pm .15 μ s, 1.5 \pm .15 μ s, 1.0 \pm .15 μ s, and .5 \pm .15 μ s). The terminal shall respond to an input signal whose peak-to-peak amplitude, line-to-line, is within the range of .86 to 14.0 V. The terminal shall not respond to an input signal whose peak-to-peak amplitude, line-to-line, is within a range of 0.0 to .20 V. The voltages are measured at point A on Figure 3-9.

4.5.2.1.2.2 Common Mode Rejection

Any signals from direct current (DC) to 2.0 MHz, with amplitude equal to or less than \pm 10.0 V peak, line-to-ground, measured at point A on Figure 3-9, shall not degrade the performance of the receiver.

4.5.2.1.2.3 Input Impedance

The magnitude of the terminal input impedance, when the RT is not transmitting, or has power removed, shall be a minimum of 1000.0 Ω within the frequency range of 75.0 kHz to 1.0 MHz. This impedance is that measured line-to-line at point A on Figure 3-9.

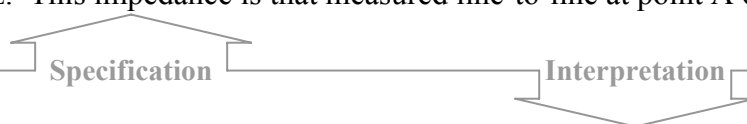

Output symmetry refers to the balance between the positive and negative signal swings of the output signal. Test messages contain the maximum number of words with specifically defined bit patterns. Input voltage specifications in MIL-STD-1553B have been revised to correspond to the revised output voltage ranges. Terminal response/no response signal levels are specified to provide a base for determining optimum threshold levels depending on the system's noise environment.

4.5.2.1.2.4 Noise Rejection

The terminal shall exhibit a maximum word error rate of one part in 10^7 , on all words received by the terminal, after validation checks as specified in 4.4, when operating in the presence of additive white Gaussian noise distributed over a bandwidth of 1.0 kHz to 4.0 MHz at an RMS amplitude of 140 mV. A word error shall include any fault which causes the message error bit to be set in the terminal's status word, or one which causes a terminal to not respond to valid command. The word error rate shall be measured with a 2.1 V peak-to-peak, line-to-line, input to the terminal as measured at point A on Figure 3-9. The noise tests shall be run continuously until, for a particular number of failures, the number of words received by the terminal, including both command and data words, exceeds the required number for acceptance of the terminal, or is less than the required number for rejection of the terminal, as specified in Table 3-II. All data words used in the tests shall contain random bit patterns. These bit patterns shall be unique for each data word in a message, and shall change randomly from message to message.



Input impedance maintained at a reasonable level, reduces signal distortion by minimizing reflected signals. Terminal input impedance is primarily determined by:

- a. *Transformer impedance*
- b. *Terminal wiring capacitance*
- c. *Secondary impedance transformation*

Noise rejection is a figure-of-merit test performed with a typical test setup shown below.

PG – Pattern Generator
1553 Xmitter – 1553B Transmitter
DC – Digital Comparator
TD – Terminal Detector

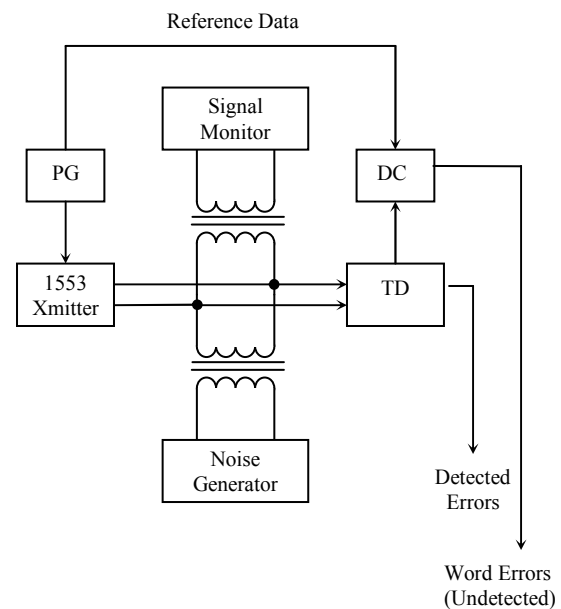

Table 3-II - Criteria for Acceptance or Rejection of a Terminal for the Noise Rejection Test

Total Words Received by the Terminal (in multiples of 10⁷)		
Number of Errors	Reject (Equal or Less)	Accept (Equal or More)
0	n/a	4.40
1	n/a	5.21
2	n/a	6.02
3	n/a	6.83
4	n/a	7.64
5	n/a	8.45
6	0.45	9.27
7	1.26	10.08
8	2.07	10.89
9	2.88	11.70
10	3.69	12.51
11	4.50	13.32
12	5.31	14.13
13	6.12	14.94
14	6.93	15.75
15	7.74	16.56
16	8.55	17.37
17	9.37	18.19
18	10.18	19.00
19	10.99	19.81
20	11.80	20.62
21	12.61	21.43
22	13.42	22.24
23	14.23	23.05
24	15.04	23.86
25	15.85	24.67
26	16.66	25.48
27	17.47	26.29
28	18.29	27.11
29	19.10	27.92
30	19.90	28.73
31	20.72	29.54
32	21.53	30.35
33	22.34	31.16
34	23.15	31.97
35	23.96	32.78
36	24.77	33.00
37	25.58	33.00
38	26.39	33.00
39	27.21	33.00
40	28.02	33.00
41	33.00	n/a

4.5.2.2 Terminal with Direct Coupled Stubs

4.5.2.2.1 Terminal Output Characteristics

The following characteristics shall be measured with R_L , as shown on Figure 3-12, equal to $35.0 \Omega \pm 2.0\%$.

4.5.2.2.1.1 Output Levels

The terminal output voltage levels shall be measured using the test configuration shown on Figure 3-12. The terminal output voltage shall be within the range of 6.0 to 9.0 V, peak-to-peak, line-to-line, when measured at point A on Figure 3-12.

4.5.2.2.1.2 Output Waveform

The waveform, when measured at point A on Figure 3-12 shall have zero crossing deviations which are equal to, or less than, 25.0 ns from the ideal crossing point, measured with respect to the previous zero crossing (i.e., $.5 \pm .025 \mu\text{s}$, $1.0 \pm .025 \mu\text{s}$, $1.5 \pm .025 \mu\text{s}$, and $2.0 \pm .025 \mu\text{s}$). The rise and fall time of this waveform shall be from 100.0 to 300.0 ns when measured from levels of 10% to 90% of full waveform peak-to-peak, line-to-line, voltage as shown on Figure 3-13. Any distortion of the waveform including overshoot and ringing shall not exceed $\pm 300.0 \text{ mV}$ peak, line-to-line, as measured at point A, Figure 3-12.

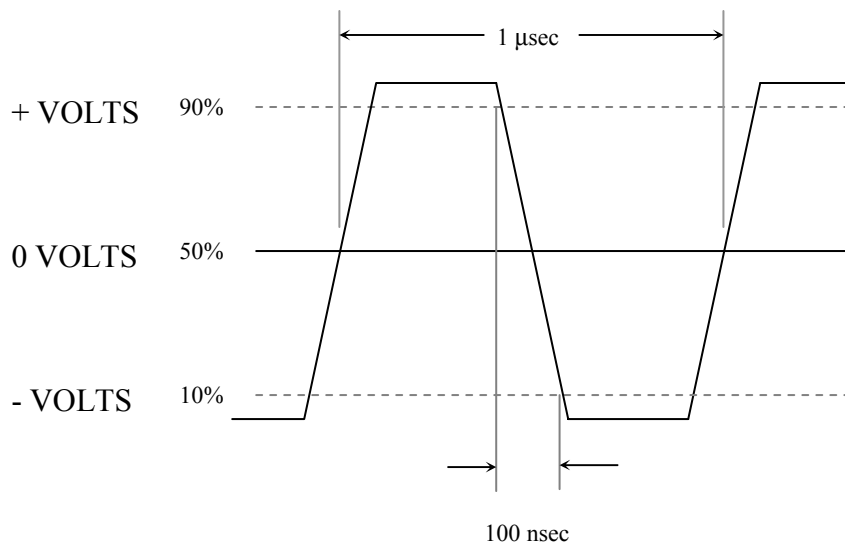

Figure 3-13 – Output Waveform

4.5.2.2.1.3 Output Noise

Any noise transmitted when the terminal is receiving or has power removed, shall not exceed a value of 5.0 mV, RMS, line-to-line, as measured at point A on Figure 3-12.

4.5.2.1.1.4 Output Symmetry

From the time beginning 2.5 μ s after the mid-bit crossing of the parity bit of the last word transmitted by a terminal, the maximum voltage at point A of Figure 3-12 shall be no greater than ± 90.0 mV peak, line-to-line. This shall be tested with the terminal transmitting the maximum number of words it is designed to transmit, up to 33. This test shall be run six times with each word in a contiguous block of words, having the same bit pattern. The six word contents that shall be used are 8000_{16} , $7FFF_{16}$, 0000_{16} , $FFFF_{16}$, 5555_{16} , and $AAAA_{16}$. The output of the terminal shall be as specified in 4.5.2.2.1.1 and 4.5.2.2.1.2.

4.5.2.2.2 Terminal Input Characteristics

The following characteristics shall be measured independently.

4.5.2.2.2.1 Input Waveform Compatibility

The terminal shall be capable of receiving and operating with the incoming signals specified herein, and shall accept waveform varying from a square wave to a sine wave with a maximum zero crossing deviation from the ideal with respect to the previous zero crossing of ± 150 ns, (i.e., $2.0 \pm .15 \mu$ s, $1.5 \pm .15 \mu$ s, $1.0 \pm .15 \mu$ s, and $.5 \pm .15 \mu$ s). The terminal shall respond to an input signal whose peak-to-peak amplitude, line-to-line, is within the range of 1.2 to 20.0 V. The terminal shall not respond to an input signal whose peak-to-peak amplitude, line-to-line, is within a range of 0.0 to .28 V. The voltages are measured at point A on Figure 3-10.

4.5.2.1.2.2 Common Mode Rejections

Any signals from direct current (DC) to 2.0 MHz, with amplitude equal to or less than ± 10.0 V peak, line-to-ground, measured at point A on Figure 3-10, shall not degrade the performance of the receiver.

4.5.2.1.2.3 Input Impedance

The magnitude of the terminal input impedance, when the RT is not transmitting, or has power removed, shall be a minimum of 2000.0 Ω within the frequency range of 75.0 kHz to 1.0 MHz. This impedance is that measured line-to-line at point A on Figure 3-10.

4.5.2.1.2.4 Noise Rejection

The terminal shall exhibit a maximum word error rate of one part in 10^7 , on all words received by the terminal, after validation checks as specified in 4.4, when operating in the presence of additive white Gaussian noise distributed over a bandwidth of 1.0 kHz to 4.0 MHz at an RMS amplitude of 200 mV. A word error shall include any fault which causes the message error bit to be set in the terminal's status word, or one which causes a terminal to not respond to valid command. The word error rate shall be measured with a 3.0 V peak-to-peak, line-to-line, input to the terminal as measured at point A on Figure 3-10. The noise tests shall be run continuously until, for a particular number of failures, the number of words received by the terminal, including

both command and data words, exceeds the required number for acceptance of the terminal, or is less than the required number for rejection of the terminal, as specified in Table 3-II. All data words used in the tests shall contain random bit patterns. These bit patterns shall be unique for each data word in a message, and shall change randomly from message to message.

4.6 Redundant Data Bus Requirements

If redundant data buses are used, the requirements as specified in the following shall apply to those data buses.

4.6.1 Electrical Isolation

All terminals shall have a minimum of 45 db isolation between data buses. Isolation here means the ratio in db between the output voltage on the active data bus and the output voltage on the inactive data bus. This shall be measured using the test configuration specified in 4.5.2.1.1 or 4.5.2.2.1 for each data bus. Each data bus shall be alternately activated with all measurements being taken at point A on Figure 3-12 for each data bus.

4.6.2 Single Event Failures

All data buses shall be routed to minimize the possibility that a single event failure to a data bus shall cause the loss of more than that particular data bus.

4.6.3 Dual Standby Redundant Data Bus

If a dual redundant data bus is used, then it shall be a dual standby redundant data bus as specified in the following paragraphs.

4.6.3.1 Data Bus Activity

Only one data bus can be active at any given time except as specified in 4.6.3.2.

4.6.3.2 Superceding Valid Commands**

If while operating on a command, a terminal receives another valid command, from the other** data bus, it shall reset and respond to the new command on the data bus on which the new command is received. The terminal shall respond to the new command as specified in 4.3.3.8.

Specification

Interpretation

This is a new section to MIL-STD-1553B to solidify requirements of the electrical characteristics and operation of redundant data buses. MIL-STD-1553A did not specify electrical isolation between redundant buses.

Single event failure refers to the routing of bus cabling, considering both physical and electrical influences, to reduce the chance of a faulty terminal or connection causing both buses to fail. MIL-STD-1553B takes into account the need for the BC to override one bus to respond on the redundant bus. Paragraph 4.3.3.8 refers to the response time requirement of an RT to a valid command.

*** Notice 2 provided clarification.*

Appendix

10. General

The following paragraphs in this appendix are presented in order to discuss certain aspects of the standard in a general sense. They are intended to provide a user of the standard more insight into the aspects discussed.

10.1 Redundancy

It is intended that this standard be used to support, rather than to supplant the system design process. However, it has been found, through application experience in various aircraft, that the use of a dual standby redundancy technique is very desirable for use in integrating mission avionics. For this reason, this redundancy scheme is defined in 4.6 of this standard. None the less, the system designer should utilize this standard as the needs of a particular application dictate. The use of redundancy, the degree to which it is implemented, and the form which it takes must be determined on an individual application basis. Figures 3-10.1 and 10.2 illustrate some possible approaches to dual redundancy. These illustrations are not intended to be inclusive, but rather representative. It should be noted that analogous approaches exist for the triple and quad redundant cases.

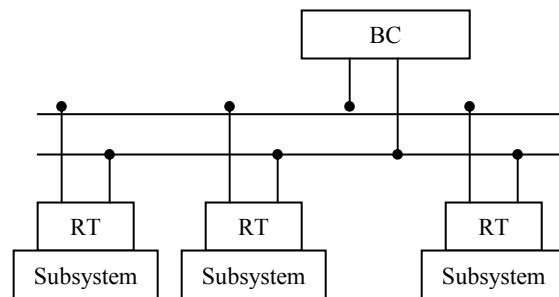

Figure 3-10.1 – Possible Redundancy

10.2 Bus Controller

The bus controller is a key part of the data bus system. The functions of the bus controller, in addition to the issuance of commands, must include the constant monitoring of the data bus and the traffic on the bus. It is envisioned that most of the routine minute details of bus monitoring (e.g., parity checking, terminal non-response time-out, etc.) will be embodied in hardware, while the algorithms for bus control and decision making will reside in software. It is also envisioned that, in general, the bus controller will be a general purpose ** computer with a special input/output (I/O) to interface with the data bus. It is of

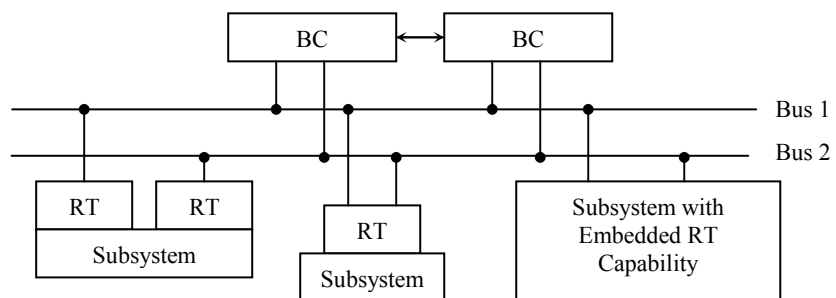

Figure 3-10.2 – Possible Redundancy

***Notice 2 changes due to incorporation of tri-service application which resulted in deletion of airborne reference.*

extreme importance in bus controller design that the bus controller be readily able to accommodate terminals of differing protocols and status word bits used. Equipment designed to MIL-STD-1553A will be in use for a considerable period of time; thus, bus controllers must be capable of adjusting to their differing needs. It is also important to remember that the bus controller will be the focal point for modification and growth within the multiplex system, and thus the software must be written in such a manner as to permit modification with relative ease.

10.3 Multiplex Selection Criteria

The selection of candidate signals for multiplexing is a function of the particular application involved, and criteria will in general vary from system to system. Obviously, those signals which have bandwidths of 400 Hz or less are prime candidates for inclusion on the bus. It is also obvious that video, audio, and high speed parallel digital signals should be excluded. The area of questionable application is usually between 400 Hz and 3 kHz bandwidth. The transfer of these signals on the data bus will depend heavily upon the loading of the bus in a particular application. The decision must be based on projected future bus needs as well as the current loading. Another class of signals which in general are not suitable for multiplexing are those which can be typified by a low rate (over a mission) but possessing a high priority or urgency. Examples of such signals might be a nuclear event detector output or a missile launch alarm from a warning receiver. Such signals are usually better left hardwired, but they may be accommodated by the multiplex system if a direct connection to the bus controller's interrupt hardware is used to trigger a software action in response to the signal.

10.4 High Reliability Requirements

The use of simple parity for error detection within the multiplex bus system was dictated by a compromise between the need for reliable data transmission, system overhead, and remote terminal simplicity. Theoretical and empirical evidence indicates that an undetected bit error rate of 10^{-12} can be expected from a practical multiplex system built to this standard. If a particular signal requires a bit error rate which is better than that provided by the parity checking, then it is incumbent upon the system designer to provide the reliability within the constraints of the standard or to not include this signal within the multiplex bus system. A possible approach in this case would be to have the signal source and sink provide appropriate error detection and correction encoding/decoding and employ extra data words to transfer the information. Another approach would be to partition the message, transmit a portion at a time, and then verify (by interrogation) the proper transfer of each segment.

10.5 Stubbing

Stubbing is the method wherein a separate line is connected between the primary data bus line and a terminal. The direct connection of a stub line causes a mismatch which appears on the waveform. This mismatch can be reduced by filtering at the receiver and by using bi-phase modulation. Stubs are often employed not only as a convenience in bus layout but as a means of coupling a unit to the line in such a manner that a fault on the stub or terminal will not greatly affect the transmission line operation. In this case, a network is employed in the stub line to provide isolation from the fault. These networks are also used for stubs that are of such length that the mismatch and reflection degrades bus operation. The preferred method of stubbing is to use transformer coupled stubs, as defined in 4.5.1.5.1. This method provides

the benefits of DC isolation, increased common mode protection, a doubling of effective stub impedance, and fault isolation for the entire stub and terminal. Direct coupled stubs, as defined in 4.5.1.5.2 of this standard should be avoided if at all possible. Direct coupled stubs provide no DC isolation or common mode rejection for the terminal external to its subsystem. Further, any shorting fault between the subsystems internal isolation resistors (usually on a circuit board) and the main bus junction will cause failure of that entire bus. It can be expected that when the direct coupled stub length exceeds 1.6 feet, that it will begin to distort the main bus waveform. Note that this length includes the cable runs internal to a given subsystem.

10.6 Use of Broadcast Option

The use of a broadcast message as defined in 4.3.3.6.7 of this standard represents a significant departure from the basic philosophy of this standard in that it is a message format which does not provide positive closed-loop control of bus traffic. The system designer is strongly encouraged to solve any design problems through the use of the three basic message formats without resorting to use of the broadcast. If system designers do choose to use the broadcast command, they should carefully consider the potential effects of a missed broadcast message, and the subsequent implications for fault or error recovery design in the remote terminals and bus controllers.

****20. Referenced Documents**

Not Applicable.

****30. General Requirements**

****30.1 Option Selection**

This section of the appendix shall select those options required to further define portions of the standard to enhance tri-service interoperability. References in parentheses are to paragraphs in this standard which are affected.

****30.2 Application**

Section 30 of this appendix shall apply to all dual standby redundant applications for the Army, Navy, and Air Force. All Air Force aircraft internal avionics applications shall be dual standby redundant, except where safety critical or flight critical requirements dictate a higher level of redundancy.

****30.3 Unique Address (4.3.3.5.1.2)**

All remote terminals shall be capable of being assigned any unique address from decimal address 0 (00000) through decimal address 30 (11110). The address shall be established through an external connector, which is part of the system wiring and connects to the remote terminal. Changing the unique address of a remote terminal shall not require the physical modification or manipulation of any part of the remote terminal. The remote terminal shall, as a minimum, determine and validate its address during power-up conditions. No single point failure shall cause a terminal to validate a false address. The remote terminal shall not respond to any messages if it has determined its unique address is not valid.

****30.4 Mode Codes (4.3.3.5.1.7)**

****30.4.1 Subaddress/Mode (4.3.3.5.1.4)**

An RT shall have the capability to respond to mode codes with both subaddress/mode of 00000 and 11111. Bus controllers shall have the capability to issue mode commands with both subaddress/mode of 00000 and 11111. The subaddress/mode of 00000 and 11111 shall not convey different information.

****30.4.2 Required Mode Codes (4.3.3.5.1.7)**

****30.4.2.1 Remote Terminal Required Mode Codes**

An RT shall implement the following mode codes as a minimum:

Mode Code	Function
00010	Transmit status word
00100	Transmitter shutdown
00101	Override transmitter shutdown
01000	Reset remote terminal

****30.4.2.2 Bus Controller Required Mode Codes**

The bus controller shall have the capability to implement all of the mode codes as defined in 4.3.3.5.1.7. For Air Force applications, the dynamic bus control mode command shall never be issued by the bus controller.

****30.4.3 Reset Remote Terminal (4.3.3.5.1.7.9)**

An RT receiving the reset remote terminal mode code shall respond with a status word as specified in 4.3.3.5.1.7.9 and then reset. While the RT is being reset, the RT shall respond to a valid command with any of the following:

- a. no response on either data bus,
- b. status word transmitted with the busy bit set, or
- c. normal response.

If any data is transmitted from the RT while it is being reset, the information content of the data shall be valid. An RT receiving this mode code shall complete the reset function within 5.0 milliseconds following transmission of the status word specified in 4.3.3.5.1.7.9. The time shall be measured from the mid-bit zero crossing of the parity bit of the status word to the mid-sync zero crossing of the command word at point A on Figures 3-9 and 3-10.

****30.4.4 Initiate RT Self Test (4.3.3.5.1.7.4)**

If the initiate self test mode command is implemented in the RT, then the RT receiving the initiate self test mode code shall respond with a status word as specified in 4.3.3.5.1.7.4 and then initiate the RT self test function. Subsequent valid commands may terminate the self test function. While the RT self test is in progress, the RT shall respond to a valid command with any of the following:

- a. no response on either data bus,
- b. status word transmitted with the busy bit set, or
- c. normal response.

If any data is transmitted from the RT while it is in self test, the information content of the data shall be valid. An RT receiving this mode code shall complete the self test function and have the results of the self test available within 100.0 milliseconds following transmission of the status word specified in 4.3.3.5.1.7.4. The time shall be measured from the mid-bit zero crossing of the parity bit of the status word to the mid-sync zero crossing of the command word at point A on Figures 3-9 and 3-10.

****30.5 Status Word Bits (4.3.3.5.3)**

****30.5.1 Information Content**

The status word transmitted by an RT shall contain valid information at all times, e.g., following RT power up, during initialization, and during normal operation.

****30.5.2 Status Bit Requirement (4.3.3.5.3)**

An RT shall implement the status bits as follows:

Message error bit (4.3.3.5.3.3) - Required

Instrumentation bit (4.3.3.5.3.4) - Always logic zero

Service required bit (4.3.3.5.3.5) - Optional

Reserved status bits (4.3.3.5.3.6) - Always logic zero

Broadcast command received bit (4.3.3.5.3.7) - If the RT implements the broadcast option, then this bit shall be required.

Busy bit (4.3.3.5.3.8) - As required by 30.5.3

Subsystem flag bit (4.3.3.5.3.9) - If an associated subsystem has the capability for self test, then this bit shall be required.

Dynamic bus control acceptance bit (4.3.3.5.3.10) - If the RT implements the dynamic bus control function, then this bit shall be required.

Terminal flag bit (4.3.3.5.3.11) - If an RT has the capability for self test, then this bit shall be required.

****30.5.3 Busy Bit (4.3.3.5.3.8)**

The existence of busy conditions is discouraged. However, any busy condition, in the RT or the subsystem interface that would affect communication over the bus shall be conveyed via the busy bit. Busy conditions, and thus the setting of the busy bit, shall occur only as a result of particular commands/messages sent to an RT. Thus for a non-failed RT, the bus controller can, with prior knowledge of the remote terminal characteristics, determine when the remote terminal can become busy and when it will not be busy. However, the RT may also set the busy bit (in addition to setting the terminal flag bit or subsystem flag bit) as a result of failure/fault conditions within the RT/subsystem.

****30.6 Broadcast (4.3.3.6.7)**

The only broadcast commands allowed to be transmitted on the data bus by the bus controller shall be the broadcast mode commands identified in Table 3-I. The broadcast option may be implemented in remote terminal. However, if implemented, the RT shall be capable of distinguishing between a broadcast and a non-broadcast message to the same subaddress for non-mode command messages. The RT address of 11111 is still reserved for broadcast and shall not be used for any other purpose.

****30.7 Data Wrap-Around (4.3.3.5.1.4)**

Remote terminals shall provide a receive subaddress to which one to N data words of any bit pattern can be received. Remote terminals shall provide a transmit subaddress from which a minimum of N data words can be transmitted. N is equal to the maximum word count from the set of all messages defined for the RT. A valid receive message to the data wrap-around receive subaddress followed by a valid transmit command to the data wrap-around transmit subaddress, with the same word count and without any intervening valid commands to that RT, shall cause the RT to respond with each data word having the same bit pattern as the corresponding received data word. A data wrap-around receive and transmit subaddress of 30 (11110) is desired.

****30.8 Message Formats (4.3.3.6)**

Remote terminals shall, as a minimum, implement the following non-broadcast message formats as defined in 4.3.3.6:

- a. RT to BC transfers
- b. BC to RT transfers
- c. RT to RT transfers (receive and transmit)
- d. mode command without data word transfers.

For non-broadcast messages, the RT shall not distinguish between data received during a BC to RT transfer or data received during a RT to RT transfer (receive) to the same subaddress. The RT shall not distinguish between data to be transmitted during an RT to BC transfer or data to be transmitted during an RT to RT transfer (transmit) from the same subaddress. Bus controllers shall have the capability to issue all message formats defined in 4.3.3.6.

****30.9 RT to RT Validation (4.3.3.9)**

For RT to RT transfers, in addition to the validation criteria specified in 4.4.3.6, if a valid receive command is received by the RT and the first data word is received after 57.0 ± 3.0 microseconds, the RT shall consider the message invalid and respond as specified in 4.4.3.6. The time shall be measured from the mid-bit zero crossing of the parity bit of the receive command to the mid-sync zero crossing of the first expected data word at point A as shown on Figures 3-9 and 3-10. It is recommended that the receiving RT of an RT to RT transfer verify the proper occurrence of the transmit command word and status word as specified in 4.3.3.6.3.

****30.10 Electrical Characteristics (4.5)******30.10.1 Cable Shielding (4.5.1.1)**

The cable shield shall provide a minimum of 90.0% coverage.

****30.10.2 Shielding (4.5.1)**

All cable to connector junctions, cable terminations, and bus-stub junctions shall have continuous 360 degree shielding which shall provide a minimum of 75.0% coverage.

****30.10.3 Connector Polarity**

For applications that use concentric connectors or inserts for each bus, the center pin of the connector or insert shall be used for the high (positive) Manchester bi-phase signal. The inner ring shall be used for the low (negative) Manchester bi-phase signal.

****30.10.4 Characteristic Impedance (4.5.1.2)**

The actual (not nominal) characteristic impedance of the data bus cable shall be within the range of 70.0Ω to 85.0Ω at a sinusoidal frequency of 1.0 MHz.

****30.10.5 Stub Coupling (4.5.1.5)**

For Navy applications, each terminal shall have both transformer and direct coupled stub connections externally available. For Navy systems using these terminals, either transformer or direct coupled connections may be used. For Army and Air Force applications, each terminal shall have transformer coupled stub connections, but may also have direct coupled stub connections. For Army and Air Force systems, only transformer coupled stub connections shall be used. Unused terminal connections shall have a minimum of 75% shielding coverage.

****30.10.6 Power On/Off Noise**

A terminal shall limit any spurious output during a power-up or power-down sequence. The maximum allowable output noise amplitude shall be ± 250 mV peak, line-to-line for transformer coupled stubs and ± 90 mV peak, line-to-line for direct coupled stubs, measured at point A of Figure 3-12.

NOTES

Acronyms and Abbreviations

Ω	ohms
μs	microseconds
AEIS	Aircraft/Store Electrical Interconnection System
ARINC	Aeronautical Radio, Incorporated
ASI	Aircraft Station Interface
BC	Bus Controller
BIT	Built in Test
BM	Bus Monitor
CDS	Common Display System
COTS	Commercial-Off-The-Shelf
CSI	Carriage Store Interface
CSSI	Carriage Store Station Interface
dB	decibel
DC	direct current
DT/OT	Developmental Test/Operational Test
EMC	electromagnetic capability
ft	foot
GPS	Global Positioning System
HUD	Head-Up Display
I/O	input/output
kHz	kilohertz
LRU	Line Replaceable Unit
Mbps	Mega bit per second
MFD	Multi-Function Display
MHz	Mega hertz
MIL-HDBK	Military Handbook
MIL-STD	Military Standard
MSB	most significant bit
MSI	Mission Store Interface
mV	millivolts
NATO	North Atlantic Treaty Organization
NAV	Navigation system
NRZ	Non-return to zero
ns	nanoseconds
P	Parity
PC/AT	Personal Computer/Advanced Technology
PCI	Peripheral Component Interconnect
PCM	Pulse Code Modulation
PMC	Peripheral Component Interconnect Mezzanine Card
RMS	root-mean-square

Acronyms and Abbreviations (Cont'd)

RT	Remote Terminal
SAE	Society for Automotive Engineers
STANAG	Standardization Agreement
T/F	Terminal/Flag
T/R	Transmit/Receive
TDM	Time Division Multiplexing
US	United States
V	volt
VME	Versa Module Eurocard
VXI	Vmebus Extensions for Instrumentation
Z _o	impedance

APPENDIX A
MIL-STD-1553 Notice Overview



THIS PAGE INTENTIONALLY LEFT BLANK

APPENDIX A - NOTICES APPLIED TO MIL-STD-1553B

MIL-STD-1553B, issued September 21, 1978, superceded MIL-STD-1553A, issued April 30, 1975. Since MIL-STD-1553B was introduced, there have been four Notices (modifications) issued.

Notice 1 Overview

Notice 1, issued February 12, 1980, was specific to the US Air Force. It added section 20 to the specification. Section 20 was later removed and replaced by section 30 which was added with Notice 2.

Notice 2 Overview

Notice 2, issued September 8 1986, has tri-service application and supercedes Notice 1. Notice 2 changes are notated with ** throughout this document. The main change in Notice 2 was the deletion of Section 20 and the addition of Section 30. Notice 2 changes include the following key points:

- a. All Air Force buses must be, as a minimum, dual standby redundant
- b. Terminal addresses to be externally selectable.
- c. RTs and bus controllers can respond to/issue (respectively) mode codes with both subaddress/mode of 0 (00000) and 31 (11111)
- d. RTs must implement four mode codes:
 1. Transmit Status Word
 2. Transmitter Shutdown
 3. Override Transmitter Shutdown
 4. Reset Remote Terminal
- e. US Air Force is restricted from using Dynamic Bus Control mode code.
- f. The reset remote terminal mode command not to require more than 5 milliseconds to complete.
- g. The Initiate Self Test mode command not to require more than 100 milliseconds to complete.
- h. All transmitted status words shall contain valid information (including on Power up)

- i. The only Status Word bit required is the Message Error bit – unless the RT has Broadcast message capabilities, Dynamic Bus Control, RT or subsystem Built in Test functions. Then these bits are also required.
- j. Use of broadcast option restricted to mode codes but broadcast capability required in bus controllers and optional in RTs.
- k. Data wrap around capability introduced to allow the BC to test data flow through an RT's hardware, memory and cabling interface.
- l. RT to RT message time-out introduced allowing a maximum $57 \mu\text{sec} \pm 3 \mu\text{sec}$ to receive the first Data word after receiving the Command word, otherwise the message is invalid.
- m. Cable shielding to be 90% minimum
- n. Shielding of cable coupling to be 90% minimum and continuous.
- o. Actual bus impedance to be in range of 70-85 Ω .
- p. US Army and US Air Force applications cannot use direct coupled stubs.
- q. Power on/off noise restriction introduced allowing a maximum $\pm 250 \text{ mV}$ for transformer coupling and $\pm 90 \text{ mV}$ for direct coupling.

Notice 3 Overview

Notice 3, issued January 31, 1993, defined that the MIL-STD-1553B had been determined to be “valid for use in acquisition.”

Notice 4 Overview

Notice 4, issued January 15, 1996, changed the cover page for administrative reasons which included a title change. There were no other changes to the document.