

# AMC1553-x



Single, Dual or Quad Stream  
MIL-STD-1553A/B Test and  
Simulation Module for PMC



# AMC1553-x

Single, Dual or Quad Stream  
MIL-STD-1553A/B Test and  
Simulation Module for PMC

product guide



**AMC1553-x**  
Functional  
Block Diagram

## General Features

The AMC1553 family of PCI Mezzanine (PMC) modules offer full function Test, Simulation, Monitoring and Databus analyser functions for MIL-STD-1553A/B applications.

One, Two or Four independent dual redundant MIL-STD-1553A/B Databus streams are provided on the Multi Channel AMC1553-x modules. (See rear page for Part Numbers and ordering information).

An on board, sinusoidal, IRIG-B time code decoder and generator allows users to accurately synchronise multiple modules to a common time source.

The AMC1553-x modules use two high performance RISC processors, each of them supporting one Dual Channel Bus Interface Unit (BIU2), each implementing two independent MIL-STD-1553A/B Channels. The AMC1553-x offers Transformer coupling, to the MIL-STD-1553A/B Databus.

Full function driver software is delivered with the AMC1553-x cards. The optional MIL-STD-1553 A/B, PBA2000/ParaView Databus Analyser/ Visualiser Software (for Windows) plus the all new PBA.pro (for Windows & Linux) can also be purchased for use with the AMC1553-x cards.

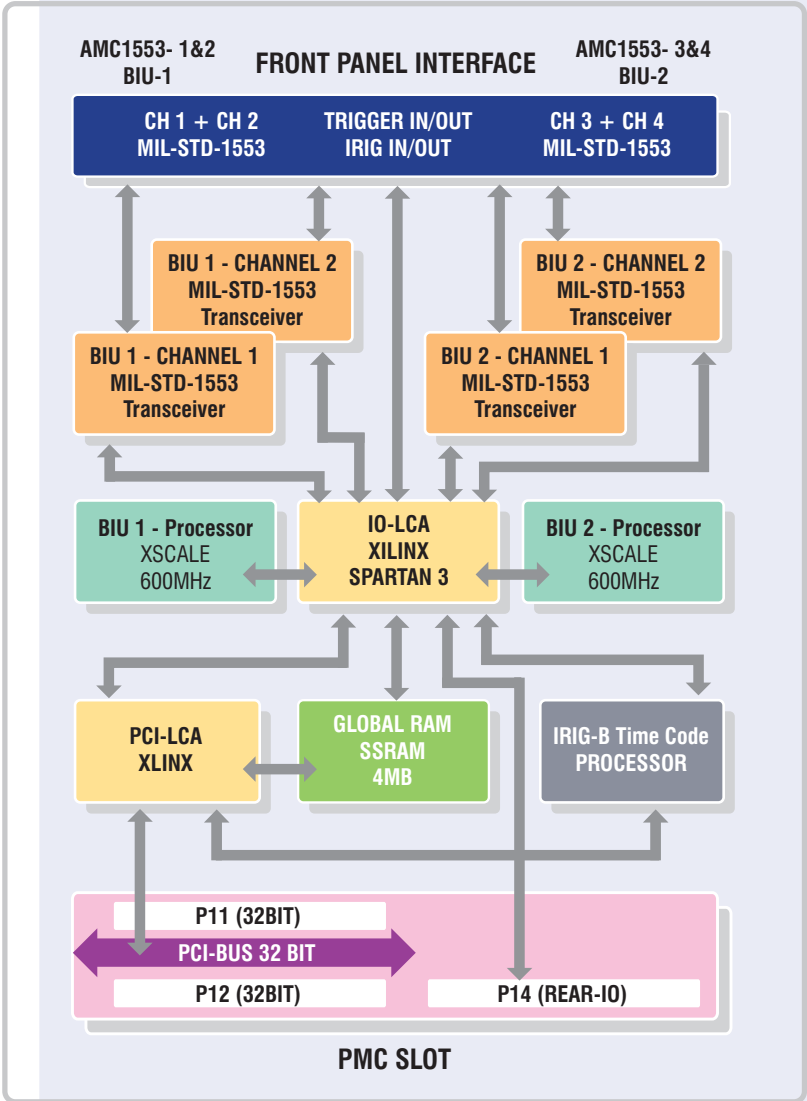

---

## Bus Controller

The AMC1553-x modules provide real time Bus Controller functions, on each independent, dual redundant, MIL-STD-1553A/B Databus Channel, concurrently with Multiple RT and Chronological Bus Monitor operation. Two 600MHz RISC processors, one for each Dual Channel Bus Interface Unit (BIU<sub>2</sub>), provides true simulation of BC operations, without Host Computer interaction.

**Key Features of the Bus Controller Mode include:**

- *Autonomous operation including sequencing of Minor/Major Frames*
- *Acyclic message insertion/deletion*
- *Programmable BC Retry without host interaction*
- *Full Error Injection down to word and bit level (AS4112 Compliant)*
- *Multi-buffering with Real Time Data Buffer Updates*
- *Synchronisation of BC operation to external trigger inputs*

---

## Multiple Remote Terminal

The AMC1553-x modules, simulate up to 31 Remote Terminals, including all sub addresses on each MIL-STD-1553A/B Channel, concurrently with BC and Chronological Monitor Operation. Alternatively each of the 31 RT's can operate in message orientated, Mailbox Monitor Mode, to monitor Non Simulated RT's.

**Key features of the Remote Terminal Simulation Mode include:**

- *Programmable Response Time for Each RT*
- *Programmable & Intelligent Response to Mode Codes*
- *Full Error Injection down to word and bit level (AS4112 compliant)*
- *Multi-Buffering with Real Time Data Buffer Updates*

---

## Chronological Bus Monitor

The AMC1553-x modules offer full bus monitoring and analysis with time tagging of all bus traffic to 1usec resolution, including response time and gap time measurement down to 250 nsec concurrently with BC and Multi RT operation.

**Key features of the Chronological Bus Monitor:**

- *100% Data Capture on each Channel*
- *Autonomous message synchronisation and Full Error Detection*
- *Two Dynamic Complex Triggers with sequencing*
- *Message Filter and Selection Capture*
- *Bus Activity recording independent from trigger and capture mode*
- *External Trigger Outputs*
- *Programmable Response Time Out*

---

## Physical Bus Interface

The AMC1553 modules provide Transformer Coupling Bus mode for connection to the MIL-STD-1553A/B Bus stub. The MIL-STD-1553A/B output voltage level is of fixed amplitude. All MIL-STD-1553A/B signals are provided at the front panel output connectors or Rear-IO Connector. (Direct coupling can be provided instead of Transformer coupling / Configuration options available at time of order).

---

## Physical Bus Replay

The AMC1553-x modules can electronically reconstruct previously recorded MIL-STD-1553A/B Databus traffic physically to the Bus. Recorded data files can be selected for a physical Bus replay to perform system integration and test with the ability to disable any or all RT responses from the recorded files.

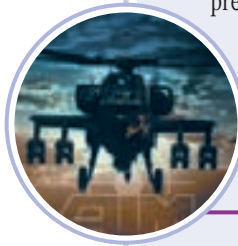

---

## Trigger/Discrete Signals

For Bus Controller (BC), Remote Terminal (RT) and Bus Monitor (BM) triggering, trigger Inputs and Outputs are provided for each MIL-STD-1553A/B Channel. The front panel Trigger signals are shared for BC, RT or BM triggers of any stream. Discrete signals are also available on the front panel. Trigger and Discrete signals are also available on the Rear PMC I/O Interface Connector. Voltage level amplitude of all Trigger signals is TTL Compatible. Discrete signals are TTL to 30Vdc.

---

## IRIG-B Time Code Decoder

AMC1553-x Modules have an on board IRIG-B time decoder and generator, with sinusoidal output and free wheeling mode for time tag synchronisation. This allows synchronisation of multiple modules to one common external IRIG-B time input source. Alternatively the on-board time code generator of one AMC1553-x module in the system can provide a timing reference for correlation of data captured across multiple Databus streams.



---

## Driver Software

The AMC1553-x modules are supplied with a BSP (Board Support Package) for Windows 2000/XP and embedded VME systems (e.g. VxWorks) comprising system drivers, application interface libraries, sample code and manuals. The VME BSP is provided in source code for integration support to the usual Operating Systems.

# AMC1553-x

Single, Dual or Quad Stream  
MIL-STD-1553A/B Test and  
Simulation Module for PMC

## AIM Office Contacts:

### AIM GmbH

Sasbacher Str.2  
79111 Freiburg  
Germany  
Tel: +49 761 45 22 90  
Fax: +49 761 45 22 93 3  
email: sales@aim-online.com

Vertriebsbüro München  
Terofalstrasse 23 a  
80689 München  
Germany  
Tel: +49 89 70 92 92 92  
Fax: +49 89 70 92 92 94  
email: salesgermany@aim-online.com

### AIM UK

Cressex Enterprise Centre  
Lincoln Road  
High Wycombe  
Bucks, HP12 3RB  
UK  
Tel: +44 1494 446844  
Fax: +44 1494 449324  
email: salesuk@aim-online.com

### AIM USA

3703 N. 200th St.  
Elkhorn,  
NE 68022  
USA  
Tel: 1-866-AIM-1553  
1-866-AIM-A429  
Fax: 1-402-763 9645  
email: salesusa@aim-online.com

## Technical Data

**System Interface:** 32 Bit / 33MHz PCIbus (Rev. 2.2) compliant

**Processors:** Two 600MHz RISC Processors

**Memory:** Up to 4 MByte Global RAM (SSRAM)

**Encoder/Decoder:** Up to Four MIL-STD-1553A/B Encoder/Decoder with full Error Injection and Detection

**Time Tagging:** Sinusoidal 46 Bit absolute IRIG-B Time stamping with 1 $\mu$ s resolution

**Trigger/Discretes:** Full Trigger configuration on Rear-IO PMC Connector P14. One Trigger Input and Trigger Output for each Channel are available with two Discretes on the front panel connector

**Physical Bus Interface:** Up to Four MIL-STD-1553B Trapezoidal Transceivers. Transformer coupled Stubs outputs, Three Trigger I/O per channel and 8 Discrete programmable Discrete (up to 30Vdc) signals available at Rear IO Connector:

- Two 15 way (female) HD-Sub
- Four Independent MIL-STD-1553A/B Channels.
- One Trigger Input and Output per channel
- IRIG-B Time Code In/Out.
- 3 x Standard PMC Connectors
- P11 & P12 for 32 bit PCI Bus
- P14 for Rear-IO.

**Dimensions:** 149 x 74 mm Standard PMC Format

**Thermal Conduction Cooling:** Enhanced Thermal performance for Conduction Cooling in Extended temperature range.

**Power Consumption:** Min. Power: 3.5 Watts (Idle Mode)  
Max. Power: 9 Watts (100% Bus Operation)  
(Typical Values for AMC1553-4)

**Operating Temp. Range:** Standard -0°C ... +60°C ambient.  
Extended temperature range -30°C ... +70°C  
Conduction cooled versions available.

**Storage Temp:** -40°C ... + 85°C

**Humidity:** 0 to 95% non-condensing

## Ordering Information

**AMC1553-1** Single Stream, Dual Redundant MIL-STD-1553A/B PMC card BC, Multi-RT Simulator & Chronological Monitor. IRIG-B Time Code. 1 MByte Global RAM.

**AMC1553S-1** Single Stream, Dual Redundant MIL-STD-1553A/B PMC card BC, Multi-RT Simulator with Mailbox Monitor. IRIG-B Time Code. 1 MByte Global RAM.

**AMC1553M-1** Single Stream, Dual Redundant MIL-STD-1553A/B PMC card Chronological Monitor and Mailbox Monitor or Bus Controller or Multi-RT and Mailbox Monitor. IRIG-B Time Code. 1 MByte Global RAM.

**AMC1553-2** Dual Stream, Dual Redundant MIL-STD-1553A/B PMC card: BC, Multi-RT Simulator & Chronological Monitor. IRIG-B Time Code. 2 MByte Global RAM.

**AMC1553S-2** Dual Stream, Dual Redundant MIL-STD-1553A/B PMC card: BC, Multi RT Simulator with Mailbox Monitor. IRIG-B Time Code. 2 MByte Global RAM.

**AMC1553M-2** Dual Stream, Dual Redundant MIL-STD-1553A/B PMC card: Chronological Monitor and Mailbox Monitor or Bus Controller or Multi-RT and Mailbox Monitor. IRIG-B Time Code. 2 MByte Global RAM.

**AMC1553-4** Quad Stream Dual Redundant MIL-STD-1553A/B PMC card: Chronological Monitor and Mailbox Monitor or Bus Controller or Multi-RT and Mailbox Monitor. IRIG-B Time Code. 4 MByte Global RAM.

**AMC1553S-4** Quad Stream, Dual Redundant MIL-STD-1553A/B PMC card: BC, Multi RT Simulator with Mailbox Monitor. IRIG-B Time Code. 4 MByte Global RAM.

**AMC1553M-4** Quad Stream, Dual Redundant MIL-STD-1553A/B PMC card: Chronological Monitor and Mailbox Monitor or Bus Controller or Multi-RT and Mailbox Monitor. IRIG-B Time Code. 4 MByte Global RAM.

**ACC-1** CompactPCI (3U) Carrier module with one PMC slot.

**ACC-2** CompactPCI (6U) Carrier Module with two PMC slots.

**AVC-2** VME (6U) Carrier Module with two PMC slots.

**ACP-1** PCI Carrier Module with one PMC slot.

© AIM GmbH 2006 • Specifications are subject to change without notice.



## General Features

The AVC-2 is a single slot, double height (6U) VME64x, extended VMEbus module with two separate PMC slots. The AVC-2 uses an on board, industry standard, Tundra chip (Universe II) providing the bridge between the VMEbus and PCIbus. The AVC-2 fulfils the requirements of the VME64x extension plus the Interface for Rear I/O. Each PMC-slot is in conformance with the Draft Standard Physical and Environmental Layers for PCI Mezzanine Cards (P1386.1/Draft 2.4).

### Key features of the AVC-2 module:

- Easily configured with any combination of PMC modules
- Combine different interface types and functions on one VME card
- User configurable base address
- Front panel LED's for VMEbus/PCIbus activity/failure display
- Fully compliant to VME64x – extended VMEbus
- Hosts PMC modules designed to PMC standard P1386.1/Draft 2.4
- Driver Software Library for VxWorks and LynxOS available

# AVC-2



VME Generic Carrier Card for PMC (PCIbus Mezzanine Card) modules

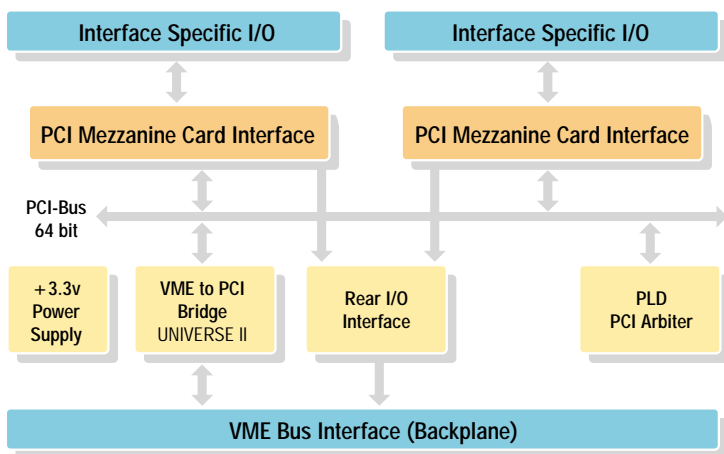

## PMC Module Interface

The AVC-2 is designed to plug all standard PMC modules with a maximum PCIbus width of 64bit operating at 33MHz.

The AVC-2 carrier board supports the + 5.0V PCIbus signalling, hence only + 5.0V tolerant devices may be used. The use of a voltage keying pin protects against false PMC assembly.

Avionics Databus Solutions



# AVC-2

VME Generic Carrier  
Card for PMC (PCIbus  
Mezzanine Card)  
modules

## AIM Office Contacts:

### AIM GmbH

Sasbacher Str.2  
79111 Freiburg  
Germany  
Tel: + 49 761 45 22 90  
Fax: + 49 761 45 22 93 3  
email: sales@aim-online.com

Vertriebsbüro München  
Terofalstrasse 23 a  
80689 München  
Germany  
Tel: + 49 89 70 92 92 92  
Fax: + 49 89 70 92 92 94  
email: salesgermany@aim-online.com

### AIM UK

Cressex Enterprise Centre  
Lincoln Road  
High Wycombe  
Bucks, HP12 3RB  
UK  
Tel: + 44 1494 446844  
Fax: + 44 1494 449324  
email: salesuk@aim-online.com

### AIM USA

600 W. Reichmuth Rd.  
PO Box 338  
Valley, NE 68064  
USA  
Tel: 1-866-AIM-1553  
1-866-AIM-A429  
Fax: 1-402-359-5410  
email: salesusa@aim-online.com

## Technical Data

**VME to PCI Bridge:** High performance 64bit VME interface

Fully compliant with PCI Standard (Revision 2.1)

VME master and slave capability

PCI master and slave capability

Integral FIFOs buffer multiple transactions in both directions

MBLT, BLT, ADOH, RMW and LOCK support

Programmable DMA controller with linked list support

Nine user programmable slave images on both busses

Four mailboxes and location monitor for message oriented systems

Eight semaphores

Full VMEbus system controller functionality

PCIbus burst size of 128 bytes

Supports coupled, posted and prefetched cycles on both busses

Provides clock speed of 33MHz with no wait states on PCIbus

Provides flexible mapping of hardware and software interrupts on both busses

Implemented using Industry leading VME to PCI Bridge device (TUNDRA UNIVERSE II).

**PCIbus:** Provides the connection between the PMC interfaces to the VMEbus Interface

Fully compliant to PCIbus Specification Rev 2.1

PCIbus width of 64 bit

PCIbus operation of 33MHz

Priority based PCIbus Arbiter

### PMC Slot 1 + 2:

Each PMC slot provides 64bit, 33MHz PCIbus operation

Each PMC slot provides the capability for Rear-I/O (VME64x Mapping)

**Front Panel:** The Front panel provides two breakouts for using the standard PMC- front panel bezel

**Front Panel LEDs:** A System Indicator Array is located at the top end of the Front Panel for indicating assertion of the SYSFAIL line, the VMEbus activity, the PCIbus activity and PCIbus errors

**Dimensions:** Double Height (6U) Board (233 x 20mm x 160mm), Single-Width

**Power Supply:** +5VDC, 2 Watts typical without any PMC module installed

**Weight:** Approx. 230g without any PMC module installed

**Temperature:** 0 to +45°C Standard Operating  
-15 to +60°C Extended Temperature  
-40 to +85°C Storage

**Humidity:** 0 to 95% (non condensing)

## Ordering Information

### AVC-2

VME (6U) Carrier Module with two PMC slots

